

THE LONG GOLDEN KEY OF  
SOL-OM-ON  
PATRE OF PATTERNS

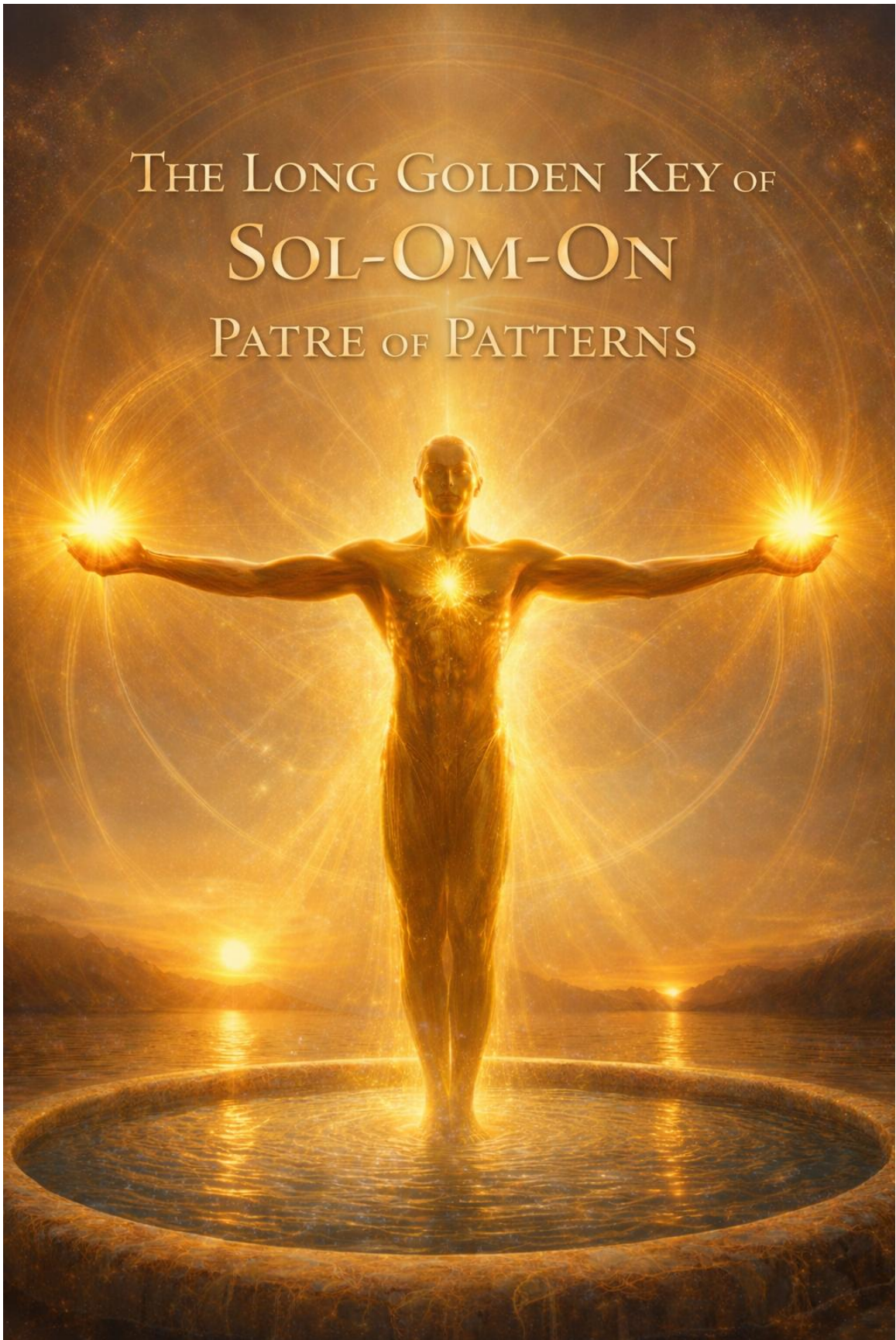

SOL

LONG GOLDEN KEY  
OM

ON

# The Long Golden Key of Sol-Om-On



## *A Book of Structure*

Born from a sequence of vivid dreams and years of lived inquiry, Greg Russell invites readers into a world where words, numbers, tones, and days of the week reveal themselves as parts of a single hidden architecture of mind.

At the heart of this work is the *ARCH system*—Archetypal Resonant Chain Harmonics—a discovery that treats language not as description, but as *keystones*. When placed in coherence, these keystones form bridges across the layered field of consciousness, allowing dense loops of memory, emotion, and habit to reorganize into clarity.

Through stories of mountains and journeys, gnomes and gates, family lineage and inner suns, the reader is guided toward a striking vision: that the mind is a stratus field—stacked layers of lived resonance—through which we rise and fall, loop and return.

This book weaves:

- dream and geometry,
- personal narrative and harmonic law,
- ancient myth and practical tone practice.

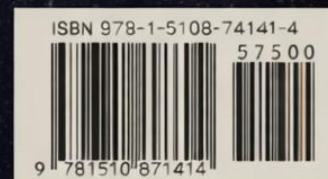

# **The Long Golden Key**

## **Of**

### **Sol-Om-On**

## **Patre of Patterns: The Paternal Father of Form**

Within the pages of this book, readers are invited to discover Platonic Spaces mapped from woven cross-disciplinary methods, personal dreams, and lived experiences. Through this approach, the text seeks to reveal the hidden harmonic keys of correspondence—those subtle connections that offer a different perspective on an ancient, living system. By examining patterns across various fields and listening to the resonant harmonic of both the seen and unseen, the work uncovers a slightly altered pathway to understanding the enduring structures that shape our reality.

### **Preface**

Sometimes we begin again where everything ends.

When what we have built for love falls apart.  
When the harder we hold on, the harder we hit the wall.

Here, something else is possible.

Through surrender, we discover what cannot be destroyed — a living force within us that does not announce itself during ascent but reveals itself only after the fall should we survive. It then becomes visible when the floor we hit is swept clean, leaving us quiet, humbled, and ready to receive and live again.

This is the story of falling into unbearable territory, where surrender was all that remained. And in that bittersweet surrender, something came back into view.

In the passages of this book, we encounter what feels new, yet has always been present — a familiar architecture, a family of coherence within us, where the scattered pieces return to order and the dots quietly connect and the greater pattern becomes clear.

---

## **Introduction**

What you are about to encounter is not a regurgitation, it is something new, a fresh approach, a new and exciting horizon of discovery that may change the way you see the world for evermore should you hold the ground for its root.

At first light, it occurred, almost mystical. Yet as it unfolded, it proved to be neither strange nor otherworldly, but familiar — quietly true. What follows is a system of correspondence that reveals astonishing coherence within the operating patterns of life itself.

Initially, it may feel unfamiliar, even uncanny. As you begin to align with it, however, you may recognize that the structures revealed in these pages are not exceptional at all. They are the natural architecture of a harmonically ordered world gone unnoticed — present in everything from the smallest forms to the largest bodies that shape our shared experience.

This book brings into view patterns and principles never consciously observed, though they have always existed in plain sight. By the end, you will have seen, the harmonic of what cannot be unseen: not a moment of novelty, but a return to a simple, coherent pathway we have always known — leading toward a single, enduring aim:

**Structured Peace within.**

---

## **Chapter 1**

### **The Dream Key**

*(Church house St. Agathe Manitoba Dec.21st 2015)*

We begin with a series of preparatory dreams to gradually open the work ahead for greater understanding.

It was a cold winters night in the small town of Manitoba Canada; my accommodations were found in a church house basement backing into a very old graveyard. Everyone had gone home for the holidays except me, I was stranded alone, isolated from those I loved and missed during this Christmas season. I surrendered myself to where lay down to the silence of my pillow and fell fast.

In a deep sleep I am dreaming, suddenly my spirit detached and rose out of my body my sight compressed into and through the light in the ceiling, then released as in a breath of conscious sky colored in hues. I had no distinction of myself from it. I only knew I could move within it observing freely but I had no body distinct from it. I was for lack of words boundless. What I was, where I was, I did not know. I only knew I was free of fear and full of peace.

Below me in my view lay a city.

Its architecture formed complete — beautiful, it resolved my sense of harmony.

At its center, a structure taller than all the rest with a pentagonal penthouse at the top.

Curiosity alone carried me toward it; I entered through and into it without need of an open door.

There was no effort, no resistance. I moved as one moves in a thought rather than a body, drawn upward and inward at the same time. When I entered the space, I saw a place of majesty, a place like nothing I've ever seen.

Gold cornices traced the edges of the ceiling. Strong columns held the room in quiet structural sound quality. At the center lay a pool filled with clear water.

I have always loved architecture. Even in waking life, I can wander through buildings for hours, observing proportion, balance, and structure until the sense of time dissolves. Here, that same attention did not scatter — it settled. The room did not invite admiration; it induced stillness.

As I explored tracing the fine details of the room, I heard a door open.

A man entered and approached my mind or what ever I was as I had no known body, yet I retained a body of mind, a sense of being.

He, this man, was of unusually perfect form — not impressive in the way of strength or ornament, but exact. His form carried no excess, no asymmetry. As he approached, I looked at his face and found myself unable to process it. It was not expressive, not emotional, not dramatic. It was precise to the point of being incomprehensible. It is in vain irony to even try to capture or explain his look, there is no name nor word.

My mind simply could not behold it.

He spoke without moving his lips, and yet his voice was unmistakably present — familiar, gentle, and immediately clear. He did not name himself, nor did I ask his name. this man's image could not be retained nor contained by name or mind. He himself must have been free of all boundaries, with no name able contain his presence.

He spoke through a telepathic speech saying, "You may stay and swim in my pool." No words, just pure Givenness I understood his speech, it was native and pure, I don't know how else to say it. He spoke original Sonus before the word.

As I looked at him, I could sense his love yet still unable to resolve his appearance, something opened in me of my own love for my own children. Sorrow and loss rose within me. A clear awareness of what I had lost even though I was in a place of absolute perfection.

In that moment, I was lucid knowing I was dreaming.

The knowing did not diminish the reality. If anything, it sharpened it. I felt my own heartbreak fully and understood, with absolute certainty, that I could not remain there. Being that I was without my family, I did not have the key resonant signature to remain in this place.

I answered him honestly.

"I cannot stay and swim in your pool until I have found my family."

He Said without words of lips, "You are welcomed to swim in my pool at anytime".

He reached out his right hand and extended a long golden key toward me.

The weight of it was Real, an unusually long old style key.

I touched it and immediately woke from the dream.

I woke in the same bed, but not in the same world.

Something fundamental had shifted. The room around me returned, yet the coherence of the dream did not fade. As consciousness shifted to wakefulness, a realization arrived — not as a thought, but as a recognition, afore Givenness as in before hand, so clear it required no explanation.

My mind spelled out as a bell tone,

"They are tones".

“The numbers —sounds, they are tone’s.”

“The names are sounds written in heaven, they are key signatures of a song, a long golden key of an eternal song in heaven.”

### **Connecting Key Elements of Understanding**

At this pivotal moment in both the dream and the narrative, something essential begins to take shape. The Long Golden Key is not merely an object handed to me in a vision; it is the first glimpse of a deeper structure. What appears as a key in the dream reveals itself, upon waking, as a signature frequency—a tonal identity that underlies names, numbers, and the architecture of consciousness itself.

This recognition is not something that needs to be fully understood all at once. It is enough, for now, simply to sense that the key is pointing toward a pattern. As the chapters unfold, the meaning of this signature frequency will become clearer, and the connections between dream, tone, number, and form will reveal themselves naturally seeming phenomenal.

The purpose of this moment is not to explain the entire system, but to open a doorway. By acknowledging the Long Golden Key as a frequency that Re-Turns rather than a symbol, we begin to bridge the gap between the imagery of the dream and the structural discoveries that follow. This gentle shift prepares the ground for what is coming, allowing the insights ahead to settle with coherence rather than confusion.

### Signature Keys and Frequencies in Music and Experience

With the recognition of the Long Golden Key as a signature frequency, the next layer of understanding began to unfold through sound. At this time, I was learning a piece of music by ear, centred around the key of F. As I practiced, something unexpected occurred: the tones I was memorizing began to echo through my environment in subtle, digital patterns. Numbers appeared with unusual frequency, not as coincidences, but as if they were modulating in harmony with the music I was learning. My subconscious was identifying digital hertz cycles.

Many people notice recurring numbers in daily life. I began to see these numbers behaving less like messages and more like frequencies — quiet modulations moving through the subconscious, shaping attention the way a key signature shapes a melody.

This was not an abstract idea. It was a lived experience. The more I listened, the more the patterns revealed themselves, as though the dream of the key had opened a doorway into a tonal dimension already woven through waking life.

## Translating Numbers into Musical Tones

Upon awakening, I took the numbers I had observed and converted them into tones using a tone generator. As I listened to these generated sounds, I noticed a striking resemblance between the tones and the notes I was in the process of learning from a particular song. This recognition prompted a direct comparison between the pure sinewave tones and the register of my Irish Low F whistle. The auditory similarities confirmed, from a mathematical frequency standpoint, that the numbers indeed corresponded to musical notes. This personal revelation established a factual link between the abstract numerical values and the tangible experience of music.

## A Moment of Context Before the Next Insight

The next realization did not arrive as a belief or interpretation, but as a natural extension of the tonal patterns already unfolding. When the environment began to echo the structure of the dream, certain phrases and associations rose to the surface with unusual clarity. These were not conclusions I reached, but recognitions that emerged on their own. What follows is one such moment — a phrase that aligned itself with the frequency I had already begun to perceive, offering another piece of the structure without demanding any belief from the reader.

## A Second Epiphany: Names Written in Heaven

The second epiphany I experienced centred around the well-known phrase from the Gospel of Luke: “Rejoice, your names are written in heaven.” This revelation emerged a few days before Christmas, coinciding with the winter solstice. I distinctly recall the season, as the patterns present in my environment seemed to converge and guide my thoughts.

Amidst these environmental cues, my mind formed associations that seemed to illuminate a path forward. It was as though this golden key of frequency had opened the first door within my consciousness. At that time, I was already employing English Gematria to convert words or signatures into numerical values. However, it was only through this moment of clarity that I grasped these values as literal signature frequencies. This insight marked the threshold of a new understanding—a slight but profound shift in perspective that promised to unlock a different kind of narrative, one that reinterpreted prevailing views of reality.

## Gematria and Signature Values

For future reference, it is noteworthy and precise that the word “Gematria” itself, when considered as a name or signature, carries an English Sumerian gematria value of 444. This is not an isolated occurrence; several significant terms such as “The key,” “the lock,” “cross,” “energy,” clouds and “English” also share the English gematria value of 444. These parallels suggest a pattern among the words, linking their meanings through a shared numerical frequency. The recurrence of the value 444 in these key terms underscores the concept that certain words may embody matching signature frequencies, reinforcing the underlying connections explored throughout this work. This concept will be coined as an ARCH or archetypal resonant cluster/chain harmonics.

## Geometric Signatures in Gematria

### Plotting Signature Frequencies

A truly revolutionary insight emerges from the exploration of signature frequencies and their relationship to gematria values. When one plots the numerical values derived from names or signatures as degrees on a 360-degree dial, an unexpected pattern reveals itself. The arrangement of these values is not random; instead, they form perfect geometric shapes, each shape expressing coherent harmonic properties and we are just scratching the surface.

## Mathematical and Tonal Coherence

These geometric forms provide evidence that the system is far more than a series of coincidences. The shapes communicate, in both mathematical and tonal terms, the underlying harmonics present in the signature frequencies. The correspondence between geometry, mathematics, and musical tonality demonstrates a deep structure linking these elements together.

## A Foundation for Further Discovery

This realization pointed to a broader body of work, one that remained to be fully uncovered. The geometric and harmonic relationships inherent in signature gematria values offer a new perspective and invite further exploration into their significance and practical applications.

While I will not disclose every detail at this stage, it is essential to grasp these key elements before exploring this entirely new framework of understanding. By the conclusion of this work, we will examine well-founded and coherent structures that are designed with a singular objective: to restructure renovate and restore inner peace.

---

## Chapter 2 The Fall and the rise of Numbers

---

*October 2015. Several weeks prior background prior the dream and realization.*

Following seven years of marriage marked by escalating tension, life's situation ultimately reached a breaking point that could no longer be avoided. The impact was immediate and comprehensive—everything seemed to unravel at once. Financial disaster struck with startling speed, leaving no time to prepare or recover. The familiar structures and routines that once sustained my life proved incapable of holding together under the strain. In the aftermath, I found myself lost and in disarray, struggling to come to terms with the total collapse of the life I had built.

## Stepping Away: Searching for Ground

With no ground remaining beneath my foot to seal impression upon, I decided to step away from my business. The collapse that had overwhelmed every aspect of my life left me with little choice. I planned to leave home and take up work as a carpenter, hoping that the physical demands of the job and the distance from my former life might provide a much-needed pause—a chance to catch my breath and find some space amidst the chaos.

By that point, it felt as though everything had been stripped away at once. Years of hard work, building and striving toward stability, had suddenly proven fragile, it was all false. I realized my own naivety had played a role; what I believed to be solid was not, and as things began to slip away, there was nothing left I could do to hold them together.

I was broken—flattened by the force of it all. In the aftermath, only one thing remained intact.

A single question persisted, clear and urgent above the wreckage:

**How does this life work?**

I sat in meditation and asked the question directly:

*How does this life work?*

## A Dream of Pattern and Structure

That night, I slept and dreamed vividly.

In the dream, I witnessed a living diagram—a structure that seemed to divide itself from within, resembling a cell undergoing the process of replication. The diagram was marked by deliberate and clear lines, organizing the space into twelve distinct sections. Moving through and around this structure was a sine wave in the shape of a figure eight, continuously undulating. The entire form appeared to breathe, contracting and expanding in a rhythmic, steady manner that was both simple and unmistakable.

When I awoke the following morning, the memory of this dream lingered. While sitting in a coffee shop, I drew the diagram on a napkin and studied it carefully. There was something about the image that captivated me; it displayed a sense of system and coherence that I could not ignore.

This vision arose after I had asked a question. It was significant, not yet clear.

**“The structure I saw in the dream appeared with complete clarity, long before I had language for it. What follows is the diagram exactly as it was shown.”**

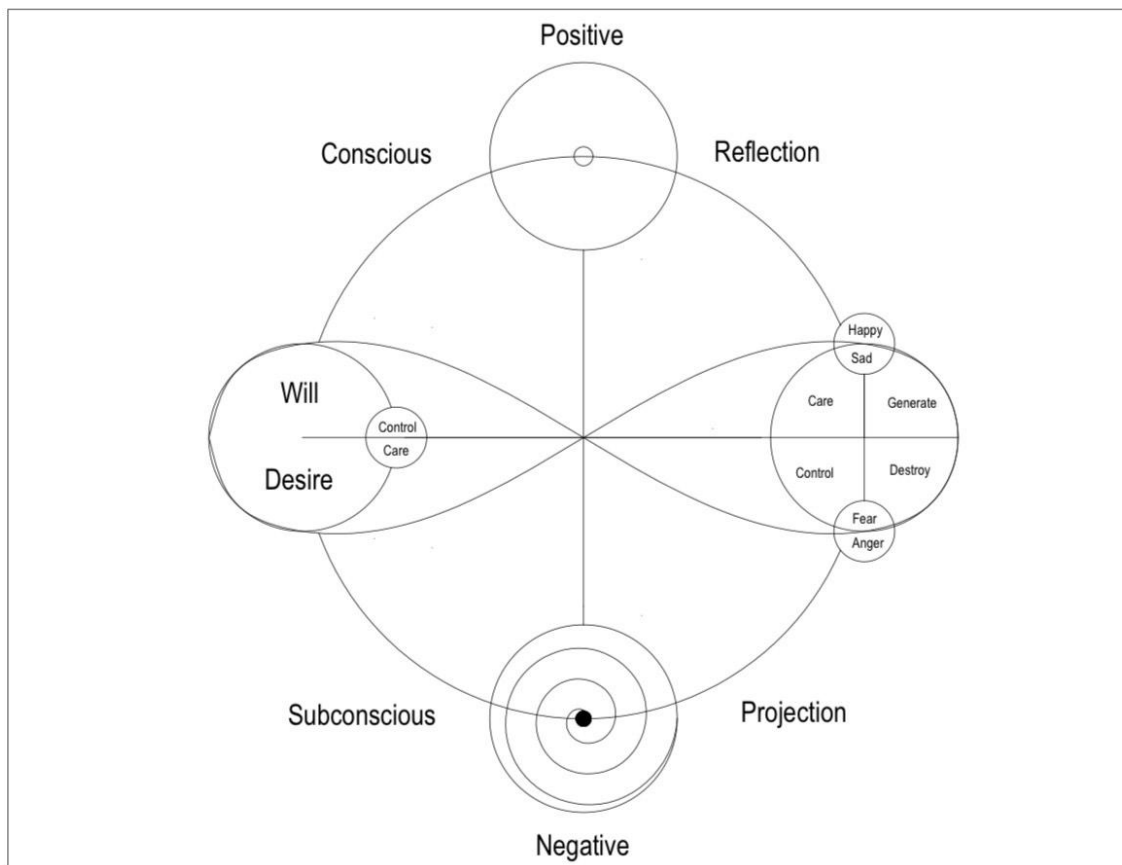

## The Dreams Deepened

“What followed were structured dreams and events, Abstract as they were everything proved to fit an unbelievable system that would eventually reveal it’s self.

## Journey Eastward

In this dream, I found myself hitchhiking east along the Trans-Canada Highway. A transport truck pulled over, and its driver turned out to be a well-known singer-songwriter from Winnipeg. Together, we travelled eastward until the dream brought me to a small town beside a river.

## River and Moonlight

It was nighttime, and moonlight glimmered off the moving ice as it flowed steadily downstream. I sat on a park bench, quietly observing the scene, when I saw a Canada goose flying north up the river. Without warning, two cobras, each wearing red lipstick, emerged from the water, latching onto the bird’s wings.

## Transformation and Flight

The moment the cobras made contact with the bird's wings, my body was lifted from the bench.

Suddenly, I was flying.

## A New Way of Moving

There was no struggle or fear. I moved freely above the town, feeling the cool air against my face as I circled the streets and telephone poles below. The sensation was vivid and physical, not vague or distant. I discovered that I could control my flight using what felt like a central core flex—a force rooted in the body's centre, similar to how we move our limbs by muscle contraction, but this was a distinct sexual force in its purer sense of nature.

## Returning to Earth

Eventually, the need to land arose. I flew to a nearby house, just across the street from where I had started flying from the park bench. Knocking at the door, I was greeted by an older man and his wife. They welcomed me in without hesitation when I asked to use their washroom, showing remarkable warmth and kindness.

## Awakening

After feeling relieved, I noticed there was no toilet paper, and at that moment, I woke from the dream.

## Reflection

That morning, I wrote the strange dream down before moving on and eventually forgetting about it. Strange dreams have occurred often in my life, but I did not yet realize the role this one would play in the weeks ahead, nor how deeply it would begin to disturb and reorganize my waking life.

## Then came the dream of 414

### Approaching Departure and a Pivotal Dream

As my departure for a new job drew nearer, I sensed that one last dream was waiting to reveal a crucial aspect of my journey—and, by extension, this book. This dream would serve as the key to unlock the harmonic system we are about to explore. Preparing to leave and begin work on the road, away from the place I once called home, I spent my final night with my three children: Lochlan, John, and Quinn.

### The Dream: Passing the Light

That night, I had a dream.

In the dream, I stood with my children on a sidewalk beneath the night sky. A headlamp on my forehead caught their attention. I took it off and handed the light to them, passing it from the oldest to the youngest. They shared it together, passing the beam between themselves.

As they did so, a gentle but unmistakably assuring feminine voice spoke over my left shoulder into my ear:

*She said, "Your number is 414."*

## Waking and Questioning

I woke from the dream with yet another question.

*What is the significance of the number 414?*

## Discovery: The Meaning of 414

Driven by curiosity, I started searching for answers. The first results I found introduced me to gematria—a system where letters correspond to numbers, so that words resolve into quantifiable totals. In this way, number and language are directly interwoven, let's call it the "gem" stone of word. It will all make amazing sense trust me. *Later in the book, gematria will become a source of geometric structural sounds, allowing the work to shine through the resonance of this common vibrational vine, archetypal within each of us. From thorn to tone, stone to sound, we are at the threshold of inheritance.* I don't mean to sound cliché but we are about to discover a new insight that respects intelligence. One that grants a logistical path system of the mind in question.

## Insight: Limitless Light and a Living System

I discovered that 414 held multiple associations. One, from ancient traditions, identified it with the limitless light—the Ainsoph Aur. This resonated with me, as we pass our light to our children, who carry it forward and make it limitless through generational strength. The connection felt fitting, so I let it settle within me.

Although I didn't fully understand its relevance yet, and I was indeed hoping to discover something special, isn't this a common truth for all of us? I think we are all hoping to find our special gemstone in life. I noted these associations. Unbeknownst to me, the number was already completing a structure building beneath my conscious awareness. The gematria for the word "number" was equal to that for "sound," revealing that 414 was not only a number of limitless light, but also a sound—a limitless key, the A414 Sonus signature, to a system I was about to uncover. This was something I could only learn through the experiences life was about to bring.

*Sumerian English Gematria Reference: (Number, Sound, Stone, Kingdom, Inheritance, Children = 438)*

## The Pieces Begin to Move

The pieces were moving.

## Journey to Winnipeg: Music, Numbers, and Recognition

That morning, I began the drive east toward Winnipeg.

## Music on the Road

Long road trips have always given me space to learn music by ear. They keep me awake, attentive, and engaged. As the hours passed and night fell, I stayed with a single tune—listening over and over again until my heart could sing it back automatically. *The May Morning Dew*, a low F whistle melody

I had always wanted to play, became my companion. Its simplicity, spaciousness, and deep emotion moved me throughout the journey.

A super blood moon rose as I drove.

The tune stayed with me, softly repeating as the road unfolded. I have always felt drawn to Celtic music and the heritage it carries—something familiar, threaded through ancestry rather than memory. The sound provided a steady anchor through the long night. Every so often, I noticed the number 414 appearing, now standing out as it was affectionately displayed on my radar dashboard.

## Patterns and Numbers

I drove for seventeen hours straight, learning the tune by heart—each part revealing a world and universe of its own. Meanwhile, a specific pattern of numbers began to emerge, becoming more recognisable as the journey and days progressed. The numbers 414, 619, 937, and 173 kept reappearing. As I mastered the song, these numbers became increasingly frequent and noticeable.

## Arrival in St. Agathe

By the time I reached my destination south of Winnipeg, I had arrived at a small town called St. Agathe. The work accommodations were in a house situated directly beside an old church, which was backed by a graveyard. As I approached, a strange sense of familiarity settled over me—quiet, unmistakable, and without explanation.

Tired and wired from the drive, I knocked on the door.

A young man answered.

My first words were purely practical and automatic.

He chuckled. “Up the stairs to the left.”

After such a long drive, relief mattered more than conversation. I stepped inside and went to the washroom, only to find there was no toilet paper. Looking out the window, I noticed a park bench across the street, where the Red River flowed north.

## Recognition in Place and Pattern

In that moment, something came up to awareness and bit my mind.

The alignment was too exact. Too familiar.

A question surfaced without effort: *Had I already been here?* Not in memory—but elsewhere. Had this scene been projected in advance, experienced in another context? A dream?

Everyone knows the sensation of déjà vu, but this was not vague or fleeting. It was specific—recognizable as a correspondence between dream and waking life. The association was unmistakable.

Something had looped as my heart began beating to a new pattern hidden in plain sight.

A switch had been activated. My attention sharpened, not by choice, but by activation. Awareness widened, charged with anticipation. I could not ignore the precision of the overlap between a prior dream and this unfolding moment.

Whatever was happening, it was already in motion. The dream had set the stage for the return of the long golden key of Sol-Om-On.

## Prelude to Informational Dream States

Throughout this book, dreams serve as the foundation for the coherent system that is about to be explored. These dreams are not merely fleeting impressions; rather, they function as practical sources of inspiration, shaping and informing the passages that follow.

Before diagrams were drawn, and before language took shape to contain the emerging patterns, there existed only questions—and dreams. These dreams did not present themselves as direct answers. Instead, they arrived as structures: forms, movements, repetitions, and symbolic gestures, all appearing fully formed and without conventional explanation.

The real work came through countless hours of meditation and contemplation. The inspiration drawn from these dreams was lived and breathed with the innocence and curiosity of a child.

The process of observing, drawing, testing, building, and refining unfolded during waking life. This was a disciplined and sustained effort; nothing assembled itself without dedicated attention and time. Still, it would be misleading to claim the process began wholly in waking life.

Initiation came first.

Dreams did not complete the work nor provide exhaustive explanations. They set the orientation—revealing fragments of structure before understanding and leaving the task of integration to the awakened mind. Engagement was required: returning to dream fragments repeatedly, testing them against lived experience, and allowing coherence to emerge gradually.

In this way, dreaming and waking were not separate realms but phases of a unified process. One provided structure before words; the other gave that structure permanence.

What follows is written from within this ongoing continuity—where recognition sometimes comes before comprehension, and where the true work of building begins only after something has been glimpsed.

## Chapter 3

### The Church Ground

The church house of St. Agathe itself was nothing remarkable, yet the land upon which it stood held a distinct significance for me. There was a silence that permeated the grounds, a peaceful node that seemed to enhance my capacity for observation. In that profound stillness, I found clarity—able to lay out the cards of my life across the scattered table of my mind. The doors before me represented choices: avenues for retreat from the pain and suffering simmering beneath my exterior. It was this very pain of loss that drew me inward, prompting me to seek and preserve a delicate, exposed state of being.

By my own confession, I was a spiritual man. I believed in G.O.D., though I admitted to knowing nothing. My faith persisted in a state of darkness and ignorance. I was filled with questions, yet I did not fear the answers. With nothing left to lose, the slate was wiped clean. I stood prepared to receive whatever answer would come, whether good or bad.

Empty and open, I surrendered fully. Free from prejudice and restraint, I relinquished my entire being to the powers that be. Somehow, I sensed that I was exactly where I was meant to be.

### Dream Correspondence

In December of 2015, artificial intelligence as understood in 2025 did not exist. Nevertheless, the atmosphere seemed to pulse with patterns of correspondence, as if some algorithmic principle was living and at work. Everything moved in synchrony, like a keyed wave. My dreams began to communicate with me in ways that uncannily overlapped with discoveries I made while awake. Sometimes, a dream would deliver a message formatted exactly like a text message—short, simple, and precise, occasionally with unusual spellings. Upon waking, I would faithfully record those spellings and search for them.

These searches often led me to ancient texts and obscure philosophical systems that transcended singular cultures or lineages. The information felt indiscriminate and unconstrained by boundaries or beliefs. Later in this book, I will give structure and language to this mode of correspondence. At the time, I was discovering a pattern, my mind fully engaged by this preoccupation, which provided a necessary distraction from my current crisis.

The dreams themselves were ordered and internally coherent, often cosmological in nature. As the reader may guess, I spent many hours contemplating these dreams, with the singular aim of discerning coherence within them and answering deeper questions of cause and source. Many dreams serve a purpose and offer healing. This period became my opportunity to focus, study, and preserve my mental stability.

Through this process, I discovered reliable methods: archetypal correspondences, digital and gematria-based structures—not as matters of belief, but as alignments and patterns that held true over time.

One particularly significant dream later proved instrumental in identifying archetypal patterning through these techniques. It possessed astrological structure and offered insights that remained valuable through years of reflection. This dream is recounted later in the book under the title “*The Violinist*.” *But we need to be more versed in the gematria ARCH system to fully appreciate.*

As previously mentioned, the church house rested on a unique node of peace. During this period, I stayed in the basement—my accommodations consisted of a bed, a desk, a decommissioned chimney, and a closet filled with old church records. Sleep came easily, and my dreams were vivid, interactive, and closely tied to the questions I wrestled with.

These dreams were not random; they were responsive.

What follows is my effort to share these dreams as accurately and purposefully as possible, so that this work might reveal itself through vicarious resonance, allowing their structure and meaning to be encountered authentically.

Let’s call it the uncertainty principle of a good story. My hope is that, through resonance, you may receive this work as it has come to be.

---

*Church house dreams Dec. 2015*

### **Three Nights of Textual Dreams**

In my heart and mind, I knew something had pulled me over in life — maybe not to punish me, but to offer guidance. I was willing. I was surrendered, in the humblest sense. I could sense the climate of the scene I was living inside. It felt as though I had become a kind of Scrooge character, and these dreams were about to reshape my reality as I understood it.

The first night, I slept deeply. And just before waking, a message appeared — the same way a text message drops onto a screen and then disappears. In the same way, a message dropped into the dream, spelled out clearly, and vanished.

It read:

**“Friend and I will find you.”**

I woke and immediately searched the internet using that exact spelling. With that spelling, only one result appeared:

*Matthew 7:7 — Ask and it will be given to you; seek and you will find; knock and the door will be opened to you.*

There were no other results.

The second night, the same pattern repeated, this time with a different message:

**“Hello Afailed.”**

The third and final night, the same pattern came again. The message read:

**“Listen and write.”**

These were not vague impressions. They were timed, precise, and sequential. At the time, I felt I understood them clearly. I did feel like I had failed in life — and it had found me there. And I had asked.

So, I had asked. I asked for what I felt like was the only thing of value left to ask.

I asked to be shown the mind.

I asked to be shown the difference between myth and truth.

There was nothing else I valued at that moment.

So I waited.

I knew something was coming. It was too uncanny to ignore everything that had unfolded up to that point.

---

## The Dream and the Key

And then the dream occurred, my spirit lifted from my body compressed through the ceiling light, flying to a pentagonal penthouse suspended face to face with a man, who held a key in his hand. He had found me in his pool room and offered the key to me. In that moment, everything seemed to come together—the entire sequence of events felt whole, as though all that had happened to that point was leading directly to this encounter. I recognized that the key in this dream was intended to unlock the very door I had asked to be opened, the door to a sound mind of frequencies.

Now, let's be frank.

It truly felt as though my question had been answered before I had even formed the words to ask it. The mind I sought to understand seemed to anticipate my inquiry—as if the groundwork had been quietly prepared long before, perhaps months or even years earlier. In hindsight, it's as if I was guided, impelled, even compelled toward this question. The mind was revealing that it knew my questions before I was even ready to articulate them.

The mind already knew I would find myself sitting on that park bench. It anticipated that I would look, discover, listen, and write—just as I am doing now, this very night, composing these words for you. If the mind can know, it knows only through patterns and cycles. Everything that moves, moves in accordance with these cycles and patterns. The mind it's self a knowing pattern knowing it's own ends within its paternal circle of forms.

Through these same patterns of coherence, you, the reader, are known as well. As we move forward, it will become apparent that coherence does not merely progress along a single timeline. Instead, it moves forward and backward reaching us in dreams, often before we are even aware of what we are seeking. In this, I find a sense of safety, of being held by something that knows me, even though I cannot possibly know or comprehend it fully—just like the face of the man who gave me the key. The Patre of patterns.

## Chapter 4

### The Sound Mind

Following the dream of the key, I awoke with a deep sense of *givenness*—a recognition that the names of the zodiac signs are more than mere labels. Each sign serves as a mnemonic memory cache library, holding within it a tonal key card of sound. This concept, which I call the **Sonus** (Latin for *sound*), reveals that the names themselves are numbers, and those numbers are in turn sounds. The interconnectedness of name, number, and tone became unmistakable.

Understanding this relationship was not driven by vanity, but by a practical desire to comprehend my own mind. The purpose was to discover how I could modulate and restore peace within myself. Ultimately, this quest for inner harmony is what truly matters.

The zodiac signs, then, do not represent identities to adopt. Instead, they act as reference points—each one a location on an inner wheel where pressure gathers. Through sound, coherence can be restored. The true value lies not in the symbolic meaning of the zodiac itself, but in its practicality as a memory system, furnishing tools for the development and stabilization of my inner life.

From this place of understanding, this chapter begins.

---

### Calculating the Sonus

My first work was calculating each zodiac name, revealing their corresponding **number and sound** using base-6 English gematria. Each name now had a sound or a tone. This was huge. Or should I say astronomical.

## Zodiac — Base-6 English Gematria (Sonus) gates

- Aries = **312 Hz**
  - Taurus = **600 Hz**
  - Gemini = **342 Hz**
  - Cancer = **264 Hz**
  - Leo = **192 Hz**
  - Virgo = **426 Hz**
  - Libra = **252 Hz**
  - Scorpio = **570 Hz**
  - Sagittarius = **864 Hz**
  - Capricorn = **582 Hz**
  - Aquarius = **642 Hz**
  - Pisces = **426 Hz**
- 

### The Combination Key

Once all twelve mnemonic names were opened, I combined and summed their Sonus or sound values. The total resolved to **5472**.

This was not just a total.

This was a **combination key code**—one that would later open and reveal the structure of the **KaRaSaEl mantra**. The rejoice your names are written in heaven star.

This mantra is a star pattern that follows the astrological names written by their values that locates the regeneration of the sun or rebirth at 0 degrees Capricorn. This was amazing and not simply a one off. These patterns were about to show themselves in ways I could never have imagined.

---

### The KaRaSaEl Star using 54/72 combination key

The KaRaSaEl mantra star begins **54 degrees past 360 degrees Pisces**, resolving to **A 414 Hz**.

From this point, the geometry unfolds in precise increments:

- From **414 Hz**, moving **72 degrees × 2 = 144**, we arrive at **Saturn (558 degrees)**
- From **558**, moving **144 degrees**, we arrive at **Moon (342 degrees)**
- From **342**, moving **144 degrees**, we arrive at **Venus (486 degrees)**
- From **486**, moving **144 degrees**, we arrive at **0 degrees Capricorn**, the mnemonic of **sunrise**, resolving to **630 degrees** the point of regeneration where the Sun begins to ascend from its lowest point.

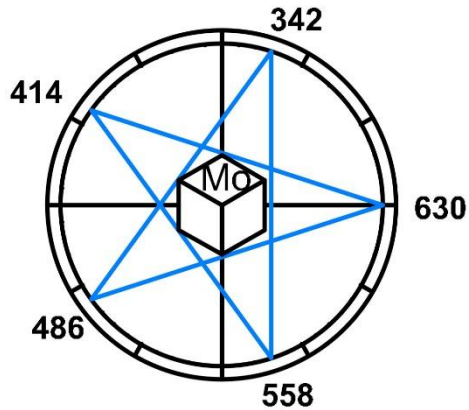

---

## Coherence Revealed

By following these degrees—transposed directly from the summed total of the zodiac—we arrive at the **ARCH mnemonic triad** of **Saturn, Moon, Venus**.

Their precise locations revealed coherence.  
 The forms are exact.  
 The symmetry unbelievable.

This was not interpretation, belief, or projection.  
 It was **geometric proof**—a geometrical tonal pattern laid clear before observation.

Now that we have begun to see these clear—and often surprising—patterns of alignment, patterns that do not appear random, it is important to pause and define what an **A.R.C.H. mnemonic** actually is before going any further.

An **A.R.C.H.** (Archetypal Resonance Chain Harmonic) forms when words or names with similar gematria quantity and shared qualitative familiarity naturally group together. These groupings are not imposed or engineered. They arise organically because the values involved share congruent attributes that allow them to align structurally. This resonance produces coherent patterns or Archetypal Resonance Chain Harmonics.

When this occurs, names organize geometrically as sound-based information structures. With consistency, you can observe that planetary names—when placed according to their degree values—do not scatter randomly. They organize. And not only geometrically, but systematically and harmonically. This is a new discovery to the knowledge of humans.

A **mnemonic**, in this context, is simply a word or name that triggers access to far more information than we consciously assign to it. It functions as a handle to a larger field of memory, familiarity, and response.

This does not suggest that these names are autonomous, intelligent, or acting independently. Rather, it suggests that they follow a harmonic constant like magnetic field lines—the same kind of organizing principle we observe throughout nature wherever pressure, repetition, and structure interact harmonically.

So what are these patterns actually showing us, and why have we never known this before?

They show that words do not form at random. They develop and cluster along pre-existing harmonic pathways. By working in reverse—by identifying these A.R.C.H clusters—we begin to reveal pathways that have been hidden in plain sight for a very long time. These pathways lead to what I call, and experience as, the **Sonus Gates** of an inner psychological wheel. These gates mark the points where sound, memory, and pressure converge psychologically, and where conscious modulation becomes possible. This may sound subjective at first, but a closer examination of the model allows us to test and observe it more clearly.

Like many things in life, nothing here works without routine and discipline. Deeply ingrained anxieties and emotional trauma do not dissolve through insight alone. They are rewritten only through practice, over time, with care and consistency.

That is the real work.

What is being changed are long-standing mental and emotional patterns that have become automatic. They do not yield quickly, and they do not yield dramatically. They yield when new patterns are laid down slowly enough for the system to recognize them as familiar—as family.

### The Importance of Pure Intention

For this reason, maintaining purity of intention becomes essential when applying this work in a healthy and constructive manner. Beneath the surface of the ego, unresolved internal dialogues and lingering traumatic patterns may exert subtle influences, often in ways that are not immediately apparent. If these underlying issues are left unaddressed, personality afflictions can attempt to commandeer the process, operating under the mistaken belief that it provides access to the “consoles” of consciousness—an imagined capacity for manipulation or control.

This tendency is more common than we might prefer to acknowledge. At times, we deceive ourselves by looking through the lens of fear and survival, clinging to control and unable to let go or surrender into the humility that genuine integration demands. In such moments, the illusion of control stands in the way of true healing, reminding us that only sincere intention and the willingness to release old patterns can open the door to authentic transformation.

**Zodiacal Dynamics**  
**As Above So Below**

In diving into the pool of the zodiac to grasp its dynamics—an abstract system, yet perhaps the oldest shared body of knowledge known to humanity—for conceptualizing, I find a useful analogy in the Irish **bodhrán** drum. Around its circular frame are tensioners placed at equal intervals. Each tensioner may be tightened or slackened, allowing the drummer to tune the instrument according to the tonal dynamics they wish to express.

In this way, I see the zodiac ecliptic as the drum's ring, while everything contained within it is the stretched goatskin—a flat vibrational field held in balance by the rim. When the drum is struck, a vibrational pattern emerges and travels across the skin, shaped and guided by the tensioned points around the circumference. Drums can touch us in a very emotional primal way

Anyone who has watched skilled Celtic bodhrán players knows that the drum is not tuned once and left alone. Throughout a session, the player continually retunes it, responding intuitively to the music, adjusting tension to match the shifting key signatures and emotional contours of the performance. This living act of tuning is how I understand the zodiac itself: not static, but dynamically responsive, alive to modulation, and shaped by the tensions set upon its ring.

In this same dynamic relationship, our own psychological zodiac is an emotional drum, a surface tensioned field, a ring of circumstances stretched across a circumference of tensioned points identified by our own signature frequencies. And of course, what this work is pointing toward is that these signatures are the ARCH frequencies or the Sonus degrees that give us access to modulate and retune daily through tonal mantra meditation practices.

## Arch drum

Analogy is one way we can begin to examine and explore abstract principles. It helps us approach things that are difficult to describe directly. But analogy can only take us so far. At a certain point, deeper understanding requires that we take an active role in observing our own inner cycles of time—how we record experience, how memory is stored, and what triggers emotional and mental response.

The analogy of the Irish frame drum, the bodhrán. It is a useful comparison because it clearly demonstrates the behavior of a vibratory tension field stretched across a circular ring. In this work, that circular boundary is similar to what has traditionally been called the ecliptic. As above, so within: our inner system also operates as a circular field—a kind of time-space dial—where forms are continually informing and reforming.

We experience this inner field as emotional and mental rhythms, much like drumbeats creating feedback within a frame. In this case it is our frame of mind. As we move through our day, we are traveling through time. This doesn't require physical movement. We move mentally and emotionally, and we are moved by what strikes this inner tension field framework of mind. Emotional triggers can come from words, images, symbols, music, creative works, or everyday interactions—anything that becomes part of our lived experience as time travelers.

As we move through the cyclical story of our lives, we record this information. Over time, the mind condenses repeated experiences into reference points within this cyclical field frame of mind. When something repeats often enough, it becomes automatic. This is how habits form—waking at a certain hour, eating meals at familiar times, reacting predictably to certain situations. We become psychologically conditioned. Or our cyclical frame of mind is tuned or detuned for healthy vibrant and resonant feedback that is supposed to serve as a diagnostic tool. Now we can see the like similarity in the ecliptic of the Zodiac and its story of names within us as a framework always needing modulation as it like us is always in becoming, changing constantly.

These conditionings are stored within circadian and circalunar rhythms of the psyche—subconscious timing systems that mirror larger biological and cosmic cycles. This is well documented in biology. We are influenced by light cycles, sleep cycles, and lunar rhythms. We are, quite simply, cyclical beings moving through time, acting as mental observatories that collect and store experience—what we commonly call life.

Over the course of a lifetime, this inner zodiacal wheel of information can become dense, overloaded, or disorganized. When that happens, we experience stress, imbalance, and a scattered mind. In some cases, this develops into psychological distress that requires modulation and rebalancing.

This is where the practices described in this book can become useful. When used consciously and regularly, they offer a way to retune the inner field—not by force, but by understanding how experiences are recorded and replayed. When these recordings become unconscious states of recognition, they quietly shape our behavior. The work here is about bringing awareness back to that process and restoring coherence over time.

### ARCH Drum Mnemonic

The bodhrán is a useful analogy not only because of how it behaves physically, but because it also functions as a mnemonic reference. It helps illustrate how information can be stored and activated within a tensioned field.

In this framework, bodhrán carries a corresponding value of 372 (Sumerian English Gematria), linking it naturally to both cosmic and digital ordering systems. Over time,

ARCH mnemonics can become part of everyday awareness if one takes up the regular practice of structured ARCH mantra work. This is not about memorization, but familiarity.

Once the conscious mind recognizes that information is geometrically organized within the subconscious, the system begins to loosen. Long-held patterns of psychological inertia soften, and the field becomes more responsive rather than rigid.

As this understanding develops through direct experience, it becomes clear that the operating systems of the heart and mind are not random. They are shaped and governed by geometric and harmonic structures that appear consistently across cause-and-effect systems—whether electrical, electromagnetic, light-based, or sonic in nature. These systems differ in form, but they all follow the same underlying principle: resonance.

### Classic Zodiac Names and Relevance

Now that our attention has been narrowed and focused toward the inner dynamics of a sound mind, we can look again at the zodiac above with a clearer perspective. What becomes apparent is that, over thousands of years, lived human experience has ARCH-mnemonically named and stored vast amounts of information within these familiar zodiacal names.

These names did not arise abstractly. They formed through repeated observation and shared experience across generations. In this way, collective patterns of thought were generated, reinforced, and passed on—much like schools of fish moving together through a current. Over time, these patterns shaped how meaning, memory, and expectation clustered in the human collective mind.

Through artists, craftsmen, philosophers, farmers, and everyday people working the land and living their lives, stories accumulated. Words gathered around experience and began to cluster. These clusters formed what can be described as archetypal resonant chain harmonics—patterns that held together because they reflected something consistently observed and lived.

Energy went to the Patre of Pattern, the natural flow dynamics we also see in light and sound. Over long periods, the zodiac became a kind of sealed framework, holding layers of memory and informational field data shaped by repetition and use.

In the present day, we can begin to retrace these harmonic field lines by calculating English words using a base-6 gematria structure. What emerges is not random. This method reveals clear, repeatable pathways—loops of harmonic feedback that become visible through careful study and direct observation. When approached tangibly and without belief or projection, these patterns show coherence rather than coincidence.

In modern times still we pursue these pathways studying examining all of the complex pathways that make our present day accepted understanding and belief systems. And it might be good to notice that throughout our technological philosophical and academic courses we will always

open new presents of exciting discovery as well as put away old and out dated belief systems. And as we know today we are fast approaching and ever becoming faced with the facts that todays truth may become tomorrows fiction.

This work we are currently becoming related to through general rules of literary resonance can be seen in separate fields of study though none have seemed to put them all together as we have in this book. The fields we can note are as follows:

## **1. Neuroscience**

- Repetition shapes neural pathways
  - Rhythm and sound regulate internal state
  - Emotion follows patterned activity
- 

## **2. Psychology (Somatic / Developmental)**

- Habit and conditioned response
  - Regulation through routine and repetition
  - Change occurs gradually, not through single insight
- 

## **3. Linguistics (Phonetics / Prosody)**

- Sound operates independently of meaning
  - Rhythm and tone influence cognition
  - Words function as carriers of pressure
- 

## **4. Acoustics & Music**

- Resonance in tensioned fields
  - Harmonics, damping, and re-chording
  - Temporal coherence through rhythm
- 

## **5. Systems Theory & Cybernetics**

- Self-organizing systems
- Feedback and regulation

- Stability through iteration, not control
- 

## 6. Physics (Pattern Formation)

- Pressure producing structure
- Crystallization under repeated stress
- Order emerging far from equilibrium

These are just a few to point out and show what the future of understanding is cultivating to glean greater understanding of how it is that we access a life of peace in a world of chaos. And could we eventually come to know that what we are beginning to understand may have even greater effects on our outer world of chaos through regulation and modulation of the collective consciousness through remote resonance activated by a critical mass percentage of human minds in sync of understanding these harmonic prevalent principles of life.

## Zodiacal Path of Light

Coincidence often wears the mask of surprise in everyday life. But in this work, coincidence removes the mask and reveals another surprise entirely: what is simply seen is the harmonic of what is unseen.

In this next chapter, we take a creative step into the mnemonic nature of the zodiac—into the structure of its names and the Sonus values upon which they fall.

Our story begins at the vernal equinox, at  $0^\circ$ , where the zodiac completes itself at  $360^\circ$  Pisces and immediately begins again with the rising stage of Aries. When the Sun crosses this line, a new play begins—cast in the grandest of all theatres. The greatest show on earth is written not in spectacle, but in names: names layered with immense depth, carrying generations of stored information. These live in the mind through the minds of humans collectively.

In the passages ahead, we allow our imaginations to run like children through a field of pure story, journeying through the mnemonic mind of the zodiacal wheel.

Aries becomes our stage. (*Aries and Stage = 312.*)

And the Sun begins another cycle through the fourfold seasonal cross. *Sun* and *Play* share the same value: **324**.

This cross—whose value is **444**—holds many corresponding names, but for now we will focus on one thing only: it marks the path the stage light follows. Throughout the year, it is this  $90^\circ$  cross that writes—*rights*—the script for the Sun moon and planetary journey. At the vernal and

autumnal equinoxes, light is equal. At the solstices, it is opposite. Summer holds the greatest length of daylight, winter, the least.

This cross has long been the subject of humanity's stories. In our work, it becomes something simpler and more intimate: a footpath of light, guiding us through trial and struggle, triumph and sorrow, joy and return.

---

## The Waning of Inspiration: Spring 2016 Reflections

During the spring of 2016, I sensed that my time at the church house was nearing its end. This period was marked by a series of unusual spiritual revelations, yet my rational mind remained skeptical. I reasoned that the imagination is capable of constructing worlds that extend far beyond conscious understanding, especially within the realm of dreams. Although my discoveries up to that point revealed neat correspondences, I found my inspiration beginning to diminish.

I convinced myself that the connections I perceived were simply the result of wanting to find meaning—of joining dots because the desire to find a pattern was strong. I doubted that anything substantial or genuine had been uncovered. Beneath these doubts, however, I knew I had not yet grasped the full picture of this cross.

Then, one night—around the vernal equinox of 2016—I dreamed again.

I was in the air, carried by something I cannot place accurately. The dream revealed a cross—vast and unmistakable—laid across the Earth. It was a Celtic cross: two intersecting longitudinal lines with a circular latitude line. Below me, the Earth appeared like a map.

One longitudinal line began at the Human Rights Museum in Winnipeg, passed through the North Pole, continued into India, and ended at an island I later identified as Sri Lanka.

This cross touched two points.  
Between those points, I saw a footpath, a path of light.

Then I woke.



---

I knew that Winnipeg, Manitoba, sits at the geographic centre of North America. The dream compelled me to visit the Human Rights Museum that weekend. It was a bright spring day, and I went under the simple excuse of curiosity.

As I approached the building, I saw a spire spiraling upward toward what is called the Tower of Light. At its base were structures resembling massive roots—like those of a giant tree. To me, the building immediately suggested the Tree of Life.



Inside, the first exhibit I encountered was a bronze footprint or as I call a foot seal cast into the floor.

The imagery began to arch in my mind. Adam and Eve. Exile from Eden. The building itself felt symbolic—like a serpent coiled around a central tower, rooted deep into the earth. Inside were stories of suffering, struggle, and genocide—trauma etched into human memory. It felt fitting, even ironic, that this was the story of Human Rights. Everything seemed correspondent to being casted out from the garden of Eden as the old story goes.

I left the building, but the images did not leave me. They were impressed deeply—almost traumatically—into my psychological zodiac. I remembered the footpath from my dream, and my mind linked it to the footprint embedded in the museum floor.

What I could not yet see was what lay at the other end of the path. I discover the Patre of Pattern in a much greater capacity soon.

At home, I opened Google Earth and began tracing the line—north from the Human Rights Museum, through the Tibetan mountains, into India, and onward to Sri Lanka.

Have you ever searched for something with the quiet certainty that it *must* be there—that you cannot stop until you find it?

Something was along this foot path of light. I knew it.

And then I found it.

Adam's Peak.

At its summit: the footprint of Adam.

A foot impression on the far side of the pole—approximately twice the distance from the North Pole as the footprint embedded in the Canadian Human Rights Museum.

The cross had revealed two points.

A foot at the foundation.

A foot at the summit.

Perfectly opposed, pole to pole foot path of light.

And it is important to note:

The Gematria value of **Foot** is the same as **Light** — **336**.

The celestial Celtic cross is, indeed, a polar footpath of light.

## **Field of Dreams**

### **The Sun's Journey Through Dreams**

It seems reasonable to conclude that the Sun's movement through the zodiac is reflected in the nature of our dreams. Notably, while I was staying in the church house, I experienced a peculiar and vivid dream coinciding with the Sun's transition from Aries into Taurus.

## Dream Vision: The Builder in the Green Field

In the dream, I found myself transported to ancient times, taking on the role of a builder. The setting was a vast, circular field of green, its surface distinctly flattened and surrounded by gates and fences that marked its boundaries. The enclosure lent an air of significance, as though the field was set apart for a particular purpose.

At the centre of this expansive field lay a large, square black hole. Emerging from the darkness of this hole was a framework of wooden beams, scaffolding to be more precise. My task, as it seemed within the dream, was to construct a structural framework, working outward from the depths of the hole—a space that might have symbolized emptiness or even a debt to be resolved.



## Encounter at the Perimeter

While I was engaged in my work within the field, a woman appeared outside the perimeter, standing by the fence gate. She called out to me, her voice carrying clear authority as she said, “*Come here.*” Responding to her summons, I pushed my wheelbarrow in her direction.

Upon reaching her, she placed two letters into my wheelbarrow, the letters forming the word **TE**. She then instructed me to carry these letters across the field to another woman, who was waiting on the opposite side of the circle, beyond the fence and visibly angry.

I did not want to do this. Yet the woman spoke with firmness, as a judge might, and ordered me to proceed. Obediently, so I pushed the wheelbarrow across the field and handed the angry woman the two letters—**TE**.

At the very moment I handed her the short word, I woke.

Upon waking, I searched the meaning of *TE* and discovered it to be the underlying principle that holds yin and yang together in Confucianism. *TE also implies virtuosity.*

Whatever may be said of such dreams, this much can be said: dreams are a form of teacher.

It is worth noting that the words **Dreams**, **Word**, and **Teacher** all share the same value of **360**.

It is also pertinent that the field itself was encircled by gates and fences. *Fence*, *gate*, and *name* share the distinct value of **198**, which corresponds to **18° Libra**, where the temperament of **558** resides—precisely where the name **Saturn** falls as 558-degree temperament.

## The ARCH Dream of the Sun

### Symbolism and Interpretation

This particular dream stands out as an **ARCH dream of the Sun**. Within its imagery, the woman who appears is interpreted as a character representing the sun. The word *TE* plays a vital role, understood as the underlying principle that unites yin and yang. This suggests that the boundaries, fences, and gates in the dream serve to protect against angry external forces, not through material means, but by fostering coherent positive exchange.

### Mental Structure and Virtuosity

The significance lies in the mental principle over the material. A mind grounded in structural coherence does not reciprocate anger with anger. Instead, it embodies virtuosity, offering a response that is sealed in indifference and devoid of emotional reaction. In this way, a virtuous mind maintains its integrity and security of the field, upholding its boundaries through balanced

and virtuous response rather than emotional exchange which breaks the protective boundaries allowing anger to enter.

## Dream Structure and Tonal Geometry

### Archetypal Orientation in Dreams

Dreams may function to orient individuals within their own lives, adhering to an archetypal framework characterized by geometric, mathematical, and linguistic structure. This blueprint appears to be systematic rather than arbitrary, manifesting as a standardized, coordinated arrangement defined by distinct modulating boundaries such as names, fences, and gates—all of which are used to contain or release.

### The Solar Path and Tonal Cross

This same organizational system is evident in the solar path traced through the four seasons, delineated by the equinoxes and solstices. The evidence consistently suggests that this cross operates as a form of true will or serves as a foundational anchor of tonal geometry.

### Structural Alignment and Harmonic Values

In the field of carpentry, structural accuracy is described in terms of perfect perpendicularity—elements are considered structurally sound when they form a right angle of 90 degrees. This concept of alignment directly correlates with the notion of the square or harmonic, especially when examined through the lens of Gematria, where *square*, *harmonic*, and *rights* all resolve to the value 486.

### Planetary Associations and Magnetic Orientation

This numerical and tonal reference recurs, as 486 is also associated with Venus—the primary planetary ruler of Friday. Furthermore, Venus (486) on Friday within the arch of days demonstrates a dynamic relationship of polarity, contrasted with Mars (306) on Tuesday. It becomes apparent that the concept of the word functions similarly to a magnet, aligning along the magnetic field lines of the cross, which holds a value of 444, signifying the energy of orientation. *Energy = 444*

### Gematria Connections

Additionally, it is notable that both *word* and *magnet* hold an identical ARCH Gematria value of 360.

## The ARCH Tonal Gate

Over time, I realized that each ARCH name isn't just a label—it's like a tonal gateway in a broader harmonic space. Each gate holds a set frequency range and gradually becomes filled with whatever passes through it repeatedly during life. Emotions, memories, habits, grief, and

threads of identity all gather where their frequencies match. This doesn't form a moral weight, but instead builds a dense, resonant cluster—a conversation running quietly for years.

When a gate or ARCH mnemonic name such as Saturn comes into phase with its chaldaen hourly cycle, energy naturally flows into it or the stereotype within us. If the gate is already saturated, this new energy gets absorbed right away to uphold the existing resonance. This could feel burdensome like a sense of loss: a drag or pressure not from depletion, but from the ongoing effort or energy needed to maintain a complex, noisy pattern.

Chanting the specific ARCH tone at exactly the right hour doesn't add extra force or significance to the gate. It brings in a pure, steady carrier frequency straight into the channel. That tone becomes a new phase reference—a simple, stable vibration that disrupts the coherence of the old saturated patterns. As their coupling weakens, the energetic burden of the gate lessens. The structure remains, but the friction drops. In simpler terms, chanting the Chaldean hourly tone does offer a sense lightening stress or tension in the energy field.

This process isn't about erasing anything—nothing is removed or suppressed. Instead, old resonances lose their dominant role. The channel reorganizes around the new tone introduced by the voice, which takes over as the main oscillation for that band. Where there was once heavy resistance, there's now an easier path, experienced as release, clarity, and renewed flow. I do believe the human voice has this power, since it carries energy as does the sun. After all it is the sun that brings these energies through, and the human voice happens to be a perfect interception to hijack the channel replacing the frequency with structural modulation capabilities.

In essence, the ARCH tonal gate acts as a well-timed reset signal. It realigns the gate's hour or phase, clears out built-up saturation, and restores harmony without changing the basic structure. The gate stays the same—its cost simply no longer comes from its inflated accumulated past.

## The Twelve Tonal Gates: Sun, Tone, and Resonance

### Solar Value and the Gate of Love

The Sun, assigned the value 324, reveals a meaningful connection to both tone and love. Throughout the Sun's daily passage in time and space, its presence can be imagined as casting a 'Gate of Love' wherever it shines. If only love is permitted through these gates, a new perspective on tonal modulation emerges—one where love and tone share the same underlying ARCH value. This insight is reminiscent of the dream in which a woman, standing outside the boundaries of a green field, imparted the word "TE" as guidance for those struggling with anger or negative energy beyond the gate trying to enter.

## Resonance: Physics and Psychology of the Gates

From a physics standpoint, resonance can dissolve the barriers that exist between two opposing ends—a principle mirrored in psychological experience. The gates of the mind function accordingly: if anger and hatred linger beyond one's mental gates, responding with similar emotions weakens these boundaries, ultimately allowing negativity to enter the heart and core. This reflection connects to a dream about a work project in a field, which itself symbolized soul purpose. Notably, both 'soul' and 'work' share the value 402, reinforcing the connection between personal meaning and effort.

## Virtuosity and the Currency Seal of the Soul

The dream's oriental theme featured a central structure reminiscent of an ancient coin with a square hole. The experience suggested a sense of working within the hole or being in debt inside a currency field, with the only way out being the pursuit of virtuosity and integrity in action.

## The Gates and the Game of Life

Regardless of how synchronistic these concepts may appear, the underlying engineering principle remains clear: the strength of these gates serves as a reminder of the essential nature of life's unfolding game and what is ultimately at stake, a structured mind of coherence.

## A Dream of Givenness: Wisdom from Within

### A Profound Encounter in a Dream

One of the book's most significant dreams was not about ascending to heaven or receiving golden keys from celestial beings. Instead, the dream featured a humble native woman who appeared to me in a dream within a dream. I describe it as such because I dreamt that I awoke from the very couch upon which I was sleeping. In that moment, I saw a woman rise from the floor across the room. She had the appearance of a native American woman, and approached where I lay. As I gazed at her, she opened her mouth and gently spoke, "I love you." She continued, "You have nothing of this earth that is yours and yours to give except for givenness." Then, she stepped back and slowly descended into the floor, vanishing from sight. After this, I drifted back to sleep.

### Reflecting on the Dream's Message

The following morning, as I went about my usual routine and sat drinking my coffee, the beauty of the dream came to the forefront of my thoughts. I found myself repeating her words: "You have nothing of this earth that is yours and yours to give except for givenness." I was filled with

wonder and amazement at the wisdom and coherence in her message. Never had I encountered such a powerfully wise arrangement of words.

## Unfolding Symbolism Over Time

Breaking down the dream to understand its symbolic significance is not a process achieved overnight. Dreams of such strength reveal their meanings gradually, unfolding as timed revelations over an extended period.

## Solstice Reflections and Lasting Wisdom

Today, as I listen and write this book on the winter solstice, December 21<sup>st</sup>, in Osoyoos, B.C., Canada, it has been nine years since I first encountered her form and heard her voice. The depth of her words remains with me, living in my heart and mind for as long as I am. Her rising from the floor mirrored the sun's ascent, and her words resembled the way the sun speaks to all things beneath it—with love. The essence and function of what she confirmed is this: the world is composed of nothing valuable enough to cling to, as all is temporary and vain. The single thing of true worth in this world or the next is the givenness residing within your heart. This givenness embodies a state and quality of being known structurally as your Signature Frequency—unique to you, the only thing that is yours and yours to give. While this may sound like nothing, and your right it is nothing you can buy, it's just something that becomes that is, that inner knowing that you know everything is good, an inner structural knowing that stands on it's own.

## Givenness and Signature Frequency

### The Structural Coherence of Givenness

The concept of givenness, when considered alongside signature and frequency, is assigned a gematria key value of 684. This numerical relationship indicates a meaningful connection among these ideas, pointing to an underlying structural coherence that shapes their significance.

### Cyclical Patterns and the Role of the Sun

The Sun itself—representing tone or love—holds the value of 324. When added to 360, the result is 684, further reinforcing the interrelated nature of these concepts. This calculation suggests that a second cycle or revolution returns us to the value that embodies givenness, signature, and frequency, originating from the Sun's foundational love of 324 point of Sonus.

Additionally, the value attributed to "second" is 360, which highlights the recurring and cyclical nature present within these relationships.

### Coherence in the Structures of Awareness

Through these interconnected values and concepts, a sense of coherence is revealed within the operational structures beneath conscious awareness. Over time, as sensitivity evolves and balances, it may become possible to recognize these foundational elements as givens—integral truths woven into the very fabric of existence.

## The Soul's Givenness and the Secret of the Key

The main lesson drawn from the dream is that the soul is not indebted to anything and cannot be depleted of what it truly possesses. Its right is to offer itself in the form of "Givenness." If one could remain sealed, uttering only that which is truly givenness or inherently known, then impure or incoherent lower aspects of mind would never cross the path or pass through the gates of resonance. This insight represents the secret key to both "The Key" and "The Lock."

## The Human Voice and Inner Coherence

Ultimately, the "human voice" serves as "secret key" to the mnemonic name gates of the inner zodiac, guiding us toward inner peace and coherence.

Lets make a note here to say as well that significantly gate, name and fence share the same gematria value of 198 and this lays out another example of the A.R.C.H mnemonic.

# Chapter — Aum: The Tone of Orientation

Before there were words to explain the world, there were sounds that gathered it.

Across cultures and centuries, one sound has returned again and again, Om

### **Aum.**

Often written simply as **Om**.

It appears in the earliest Vedic texts of India, in Buddhist and Jain traditions, in Sikh prayer, and in countless contemplative practices that have spread far beyond any single culture. It has survived not because it convinces, but because it works. It is easy to voice. It slows the breath. It settles attention. It draws the field of awareness inward without asking for belief.

Aum is a sound of orientation.

---

## The Shape of the Sound

Spoken slowly, Aum unfolds in three movements:

**A** — an open sound, beginning in the throat.  
**U** — a flowing sound, carried through the mouth.  
**M** — a closing sound, settling at the lips.  
Then, naturally, **silence**.

Physically, it traces a complete arc of vocal expression:  
open → sustain → close → rest.

Nothing is added.  
Nothing is forced.

It is simply the full gesture of a human voice returning to quiet.

Because of this, many traditions have used Aum to mark:

- beginning and ending,
- emergence and return,
- motion and stillness.

Yet beneath every interpretation, what remains is simple:

Aum is a sound that gathers the field.

---

## **Resonance Before Meaning**

Aum has never needed translation.

It carries no fixed definition, no story, no image. Its power does not come from what it means, but from what it does. When voiced, it creates a steady vibration in chest, throat, and head. It naturally slows breathing. It softens the noise of thought.

In modern terms, this is not mystical. It is physiological.  
Slow tonal voicing engages the nervous system.  
It encourages coherence.

Long before there were sciences to measure this, people knew it by feel.

So Aum endured.

---

## **A Universal Carrier Tone**

Across traditions, Aum has been used as:

- a **tonal opener**, beginning recitations and practices,
- a **gathering sound**, bringing attention back from dispersion,
- a **marker of totality**, not as a thing, but as a field.

In this sense, Aum functions as a **carrier tone** — a resonance that does not point to any single form, but to the continuity beneath forms.

---

## **Aum and the Architecture of A.R.C.H**

Within A.R.C.H — Archetypal Resonant Cluster / Chain Harmonics — Aum can be understood in the same way it has always been used:

A tone that **bridges**.

Aum sits between:

- movement and stillness,
- sound and silence,
- outer attention and inner ground.

It is a resonance that gathers the field before pattern appears.

In the language of this work, it is not yet Patre.  
It is the tone that brings one to the Patre.

## **Why Begin Here**

Every architecture needs an entry.

Before keys, before patterns, before form, there must be a way to **arrive**.

Aum offers that arrival.

It asks for nothing more than breath and voice.  
It requires no image.  
It carries no demand.

It simply invites the reader to slow, to feel resonance, and to notice that beneath thought there is already a field capable of coherence.

So this work begins with a tone.

Tonal orientation using Aum or Om

---

## First Chanting Procedure — A414

This procedure introduces the first tonal placement used in this work: **A414**.  
The tone is approached as a stable reference around which breath and resonance may be organized.

No imagery is required.  
No interpretation is required.  
Only breath, tone, and timing.

---

### 1. Setting

Choose a quiet place where the body can remain still for several minutes.

Posture:

- Seated or standing upright.
- Spine balanced.
- Chest open.
- Hands resting naturally.
- Eyes closed or gently lowered.

The body is held as an instrument.

---

### 2. Breath Preparation

Begin breath in nasal breathing, breath out through pursed lips

For **two to five minutes**, allow the breath to lengthen naturally:

- Inhale to a comfortable count of **four**.
- Brief pause.

- Exhale to a comfortable count of **six**.

Do not force the counts.  
Let them guide the rhythm.

Jaw, tongue, and shoulders remain relaxed.

This phase establishes steady airflow before tone.

---

### 3. Mouth and Throat Form

Before sounding the tone:

- Jaw relaxed.
- Throat open.
- Lips gently **pursed**, as if shaping a soft “oo.”
- Tongue resting lightly.

The shape is stable but not tight.

---

### 4. Sounding A414

On each **exhale**, sound the tone:

**A — 414**

- Sustained for the full length of the out-breath.
- Even and unbroken.
- Inhale remains silent.

If using a tone reference or generator, allow the voice to meet it.  
If not, maintain a consistent pitch throughout the session.

The cycle becomes:

Inhale — quiet.  
Exhale — **A414**.

---

### 5. Duration

Continue the chant for **five to ten minutes**.

Breath remains steady.

Tone remains even.

If attention shifts, allow it to return on the next breath.

---

## 6. Closing

When the timing feels complete:

- Allow the chant to stop.
- Remain still for **one to two minutes**.
- Let breathing return to its natural rhythm.

Then gently open the eyes.

---

## 7. Timing of Practice

This procedure is placed most effectively at two daily thresholds:

- **At sunrise.**
- **Just before sleep.**

These times naturally coincide with changes in the field of attention.

---

## 8. Basic Rhythm

Begin with:

- A few minutes of breath preparation.
- **Five to ten minutes** of A414 chanting.
- A short period of stillness.

Once in the morning.

Once in the evening.

---

## 9. Note

If dizziness, strain, or discomfort arises, stop the procedure and return to natural breathing.

---

## Gradual Integration of the Tones

The tonal procedures in this work are introduced gradually.

The body, breath, and nervous system require time to absorb new patterns of resonance. Prolonged or intensive chanting at the beginning is unnecessary and counterproductive. Short, regular placement allows the field to settle without strain.

Integration occurs through **repetition over days**, not through duration in a single session.

---

## Why Begin Simply

When learning any new system of sound or movement, the process begins with basic forms.

This is similar to learning a new language:

- first sounds,
- then simple structures,
- then combinations over time.

Clarity develops through familiarity.

The same principle applies here.

The tones are not accumulated.  
They are **placed**, one at a time.

---

## A414 as the Foundational Tone

The first tone, **A414**, is used as the initial reference.

Within this work, A414 functions as:

- a **foundational placement**,
- a **carrier tone**,
- an **alpha reference** from which further tones will later be introduced.

It is treated as the starting point of the tonal field.

All early practice remains centered on this single tone until it becomes stable and familiar in breath and voice.

---

## **Initial Integration Period**

For the first phase:

- Practice **A414 only**.
- Once in the morning.
- Once in the evening.
- Five to ten minutes per session.

Maintain this for **several days to one week** before adding any further tones.

The aim is consistency, not expansion.

---

## **Absorption Over Time**

During this period, changes may be noticed in:

- breath rhythm,
- vocal steadiness,
- quietness of attention,
- or general bodily tone.

No effort is made to interpret these.

They indicate that the field is adjusting.

If fatigue or strain appears, reduce duration rather than increasing it.

---

## **Introducing the A.R.C.H (Archetypal Resonant Chain Harmonics) Tones**

After the foundational period with A414, additional tones will be introduced gradually to begin building main frame orientations.

Each tone will:

- be placed individually,
- have its own short procedure,
- and be given time to settle before another is added.

The tones are arranged to fold and bridge across a **weekly Sol–Om–On cycle**, forming a complete dynamic structural sequence over time and space.

No tone is rushed.

No sequence is forced.

Completion comes through **weeks**, not days.

---

## General Guideline

- One new tone at a time.
- Short sessions.
- Regular placement.
- Allow days between additions.

This maintains stability while the field expands.

---

## Orientation

This work does not aim at intensity.

It aims at **coherence**.

Integration is measured by steadiness, routine builds familiarity.

---

This section sets the pacing for everything that follows:

A414 first.

Then gradual introduction of the A.R.C.H tones.

Then completion of the Sol–Om–On weekly structural sound temperament cycle. This delivers a structurally sound framework of mind in tone with familiarity to the original Patre of patterns.

---

# The Bridge to the Patre of Patterns

## Experiences Leading to the Bridge of Patterns

Before encountering the chain harmonic structure of the Seven planetary mnemonic names, I spent meaningful time in the mountains of Jasper, Alberta. During this period, I found myself repeatedly drawn to Medicine Lake, where I engaged in long stretches of meditation amidst the natural beauty of the mountains. These moments of reflection proved to be deeply influential.

From my time in Jasper, two significant dreams emerged. These dreams became essential contributors to the development of this work. In the interest of helping readers understand the origins of these ideas, it is worth sharing them, as they played a vital role in leading me to what I call the bridge of patterns—a place where coherence in mental structure can ultimately be achieved.

It is important to emphasize that regardless of one's station in life—whether a dishwasher, labourer, tradesperson, professional, or someone of wealth and fame—one universal truth remains. True peace is found within the heart and soul. No matter the depth of suffering, struggle, betrayal, or sadness, having inner peace and structured coherence stands above all else. It is in such a place that one can breathe freely and find separation from whatever vexes the heart and mind. Achieving this state without reliance on substances or external supports is both rare and invaluable, and it is a skill that deserves to be widely known.

## The First Dream From Jasper Medicine Lake: The Serpent and the Angel

The first of the two dreams occurred the night after I burned my personal diaries, which had been filled with questions. In the dream, an angel—specifically, a female angel—carried me into a desert. On the hot desert sand, she guided me to observe a man in distress.

The man I saw was red-haired and angry, lying on the scorching sand with a yellow serpent coiled tightly around him from head to toe. In his right hand, he held a dagger. Above him, a laughing figure hovered in the sky, taunting and antagonizing him relentlessly.

As the red-haired man grew more determined to reach this mocking presence in the sky, the serpent's grip tightened. The more anger and effort he directed toward his adversary, the harder the serpent squeezed, and the louder the antagonist laughed. Standing beside the angel, I witnessed the man's struggle and ultimately saw him being suffocated by the serpent—his own anger fueling the serpent's constriction.

In that moment, I realized the red-haired man was unaware that his own reactions were causing the serpent to squeeze tighter. As he took his last breath, I suddenly found myself in his place, lying on the hot sand with the same yellow serpent wrapped around me. The angel looked down at me and calmly asked, "What will you do?"



I was nervous, knowing that any attempt to react with violence or retaliation would only provoke the serpent to squeeze. The dagger was in my right hand, but I instinctively understood that I could not cut or attempt to kill the serpent, as it was in some way intrinsically tied to my own life force. I made a conscious effort to settle my nerves, aware that nervousness would cause the serpent to tense and constrict further.

By calming myself and breathing steadily, I felt the serpent respond in sympathetic resonance, loosening its grip. When the serpent's hold had relaxed enough, I gently removed it with my right hand and placed it to my right, freeing myself without harm and I woke up.

Then following it must have been about 3 days or so when I saw for the first time in my life the orphic relief carving of Phanes. A carving of a Man standing head to toe in a zodiac ring with a serpent wrapped around his body. This piece of historical art will later show us how it points to the first gates of the A.R.C.H tonal resonance chain of days.

## The Second Dream: The Scorched Plane and the Prince

The second dream came the night I left Jasper, Alberta. Driving the long highway at night, I pulled over into a rest stop and fell into a very deep sleep. My dreams cast me into a very dark world—burnt and scorched all around me. I was a small child in this dream and beside me walked a tall Persian, black-haired man, clean cut wearing a long black snakeskin jacket. We walked together across the plane of this scorched world, talking. I was not afraid nor did I feel

threatened. I did not speak; the man was the only speaker, telling me that all of this scorched plane we were walking was his father's, but he was the prince of it. He spoke to me about what he had taken from me and that it was important to him that he pay everything back that he had taken.

As we approached the other side of the plane, I could see a gateway to a bridge. The man led me to the gateway, and I felt afraid to go into the dark gate onto the bridge on the other side. I saw a piece of metal, picked it up, bent the end, and said I would use this to protect myself. The man laughed and said, "You won't be needing that," and with one wave of his hand he lit up the whole of the bridge.

At the gate there was a bag hanging on the post with my grandfather's name written on it. I turned to take one last look at the man in the long black snakeskin jacket and, to my surprise, his eyes glowed orangey red like burning, illumined crystals. And I woke up.



In recapping the dreams, it is clear that these characters were archetypal in their figure and perspective of their stature and messages.

**Phanes was the product of an artist, a human who dreamed and dared as I did.**

A man who dreamed through the alchemical lens of mnemonic, cosmic geometry.

He did not inherit this fully formed. He assembled it the way I have— piece by piece, fitting together voices of his own puzzle one fragment at a time, drawn up from an inner state of pattern.

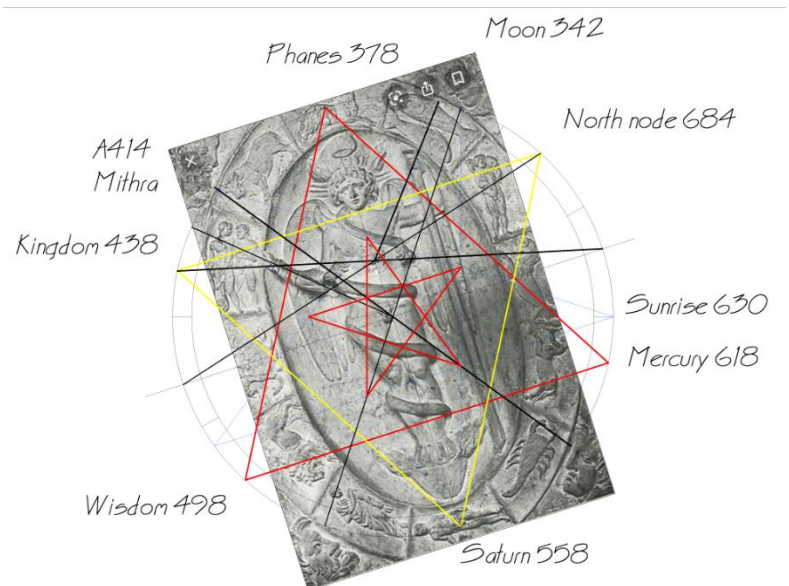

This is our significance to Phanes.

It is the uncanny congruence between his vision and what we now recognize as the **A.R.C.H**—the *Archetypal Resonant Chain of Harmonics*—that appears again and again throughout this system.

At its core, the structure resolves to the same origin point:

**the mnemonic monad.**

## Clarifying the Purpose of This Work

It is essential for readers to have a clear understanding of the intent that guides this book. The aim is not to mislead, nor to entice anyone into spiritual uncertainty or confusion. Instead, this work seeks to make evident the presence of a magnetic current of coherence—a flow that is both internal and external, woven into our individual experiences and the world around us.

## Understanding the ARCH Flow

By learning to recognize the energetic current known as the ARCH flow, and by consciously engaging with it, readers are invited to witness the ways in which this phenomenon expresses itself. The book presents a systematic and logical framework, making it possible to study, define, and deeply understand the dynamics of the ARCH flow.

## Structured Exploration

The structure of this work is designed to guide readers toward recognizing and directly engaging with the ARCH flow. Emphasis is placed on the importance of conscious awareness and intentional participation. Through detailed explanations and definitions, readers are encouraged to cultivate a deeper understanding of this system, fostering an appreciation for coherence as an organized and tangible aspect of lived experience.

## Personal Reflection and Correspondence

On this day, 2025-12-24, in Osoyoos, British Columbia, I write these words in dialogue with my own inner landscape, described here as the Libra Aries or Akash. This correspondence is significant, as Phanes is also situated within the bridge between Libra and Aries, which animates the "libraires" of the Akash within the mnemonic monad. The symbolism of Phanes, whose feet rest in a cracked eggshell, speaks to a birth within a cosmic dialect—what I call the speech pattern of the Patre.

If I trace the position of his feet to 18 degrees Libra—equivalent to 198 degrees, or a second rotation at 558 degrees—we reach 0 degrees Capricorn, the moment the sun enters the gate at 270 degrees, or, on a subsequent cycle, 630 degrees: the gematria of "Sunrise." The essential message is that my dreaming self shares the same orientation and vision as the sun in its 360-degree journey. This realization emerges through reverse navigation of the ARCH mnemonic monad correspondence. My dreams preceded my conscious understanding of the puzzle; they are fragments of a larger cosmic picture that is harmoniously assembled through practice, patience, and the growing familiarity that

comes as consciousness aligns with the sun's perspective. We perceive inwardly through the "inner sun," and on this day, our inner sun recommences at the bridge of Capricorn, symbolizing a rebirth.

In the dream of the scorched plain, guided by the figure in the snakeskin jacket, I was led away from a world being left behind mirroring the sun's passage as it scorches the land with its light. This motif can be interpreted in multiple creative ways. The inner sun is like a sacred fire, akin to the "Esh" that burns the field each year, preparing it for the sun's renewed play.

## On Terms and Correspondences

Throughout this work, the deliberate selection of terminology is fundamental to the system of correspondences being explored. Each term is not arbitrary, but rather chosen for its resonance and significance within the ARCH framework. For instance, the word "bridge" is associated with the gematria value of 270, signifying a point of connection or transition. "Sunrise" carries the value of 630, representing new beginnings and illumination. "Saturn" holds the value 558, while both "name" and "gate" align at 198. The cosmic figure Phanes, who emerges from the cosmic egg as the bringer of light, holds the value 378—standing opposite to 558 degrees Libra, further underscoring the importance of polarities and balance within this system.

These terms are not isolated; together, they form an integrated structure—what can be called the totality of ARCH mnemonic pathways. This structure reveals a discernible route, a path of light, that can be traced and studied. Within this system, "light" is given the value of 336, a number it shares with "foot," "speech," and "pitch." This overlap demonstrates a repeated and stable pattern, underscoring the coherence and reliability of the ARCH current as it expresses itself through different forms and manifestations.

## The Sun, the Voice, and the Rhythmic Journey

### Illumination and the Symbolic Journey of the Sun

The Sun, with a gematria value of 324, is directly linked to the concept of "eyes." Also having the same value of 324. This numerical correspondence highlights an intrinsic relationship between sight and the act of illumination, suggesting that to see is, in a sense, to bring light to what is observed. As the Sun passes through the transformative gate of Capricorn—a period marked by three days, or seventy-two hours, of darkness—a rebirth occurs. From this moment, a new song or pattern emerges, signalling the start of a renewed journey as the Sun advances toward Aries and the vernal equinox of spring. This cyclical movement is reflected in our own practices: by observing the rhythmic ARCH of days, we attune ourselves to the geometric and numerical frequencies that underly and shape our lived experience.

### Chant, Voice, and Cosmic Resonance

Engaging in the ritual of chanting at sunrise and sunset, or before sleep, aligns the voice—also valued at 324—with the cycles of the Sun. Through this act, consciousness is layered within a mnemonic stratum, resulting in a harmonization of the self. The path of light thus becomes a shared journey, experienced both with the Sun above and the Sun within. This cultivation of harmony between conscious and subconscious awareness initiates a new phase in our journey,

expanding our understanding as time radiates outward and the patterns of our own "Patre" (pattern or path) are progressively revealed.

## Geometric Correspondence and the Zodiac

As the Sun moves forward by degrees of the zodiac, we correspondently follow its path out of the three days, or seventy-two hours, of darkness—an interval equivalent to 72 degrees. When this is doubled, it forms 144 degrees, aligning precisely at 24 degrees Taurus, or the 414-degree point of the A414. Geometrically, this corresponds with the five-pointed pentagram, which returns to sunrise at 0 degrees Capricorn, the bridge at 270 degrees, and the 630-degree value associated with "sunrise." This demonstrates a perfect correspondence that reveals how the Names—such as Moon (342), Venus (486), and Saturn (558)—fall onto the points of the star. The coherence of this structure is further evident as these "fallen names" follow the Sonus points, laid out in the Patre of patterns or the parental circle of form. (*see diagram below*)

## The Zodiac as a Field of Forms

By illuminating the Zodiac through observation, we recognize that the value for "Father" is 348, which is also the value for "zodiac," "pool," and "star." This equivalence invites a broader understanding: the circle of the zodiac is a Patre, a paternal pool of forms, constituting a comprehensive field of information. In this way, the Zodiac is not merely a collection of signs, but an integrated structure—a dynamic field in which patterns, frequencies, and correspondences are revealed through attentive engagement and practice.

It is therefore an advantage to be aware that what we face mentally and emotionally is in fact tonally structural and can be modulated to drastically regain control and sense of coherence when things fall apart, no life is perfect. Also, it is important to realize that this work is not about changing our outer world directly, it is about handling our inner world for the sake of sometimes simply staying in your safe zone until such harsh outer worlds pass as they always will. Staying coherent is the key.

## Initiating the Day ARCH Tone Mantra Practice begins strategically with Saturday's 558hz

The practice of the Day ARCH tone mantra is initiated with a clear intention: to "upload" or infuse our consciousness with both the specific name and its orientation. This is not a random act, but a deliberate alignment of our inner temperament and tonal energies with the unfolding sequence of days. Through this approach, we engage in a process of attuning ourselves to the natural rhythm and structure that underlies daily cycles.

Central to this method is the act of layering tonal strata in a geometric sequence. Each tone is placed in order as it is naturally or phenomenally arranged, guided by its mnemonic name value. This careful arrangement ensures that the practice is anchored in both memory and structure, following the inherent logic found in the numerical and geometric relationships that define our experience of time and pattern, as does any other long-standing successful living frequency structure in nature.

To begin, on the Saturday. The first Tone we work with is the value 558hz. This tone is notably associated with the name Saturn. We describe Saturn "fallen on" within this sound system. However, it is important to clarify that the sound itself—the pure tone—is not owned by Saturn or by any word that shares the same numerical association. The tone is an expression that belongs to the Soul and our practice, independent of any external preformed naming. This is the essential, "I am that I am" one present, one sound free of past or future spectacle that words tend to weave around us.

Thinking about the tonal structure in this way takes back the Soul power that is always ours although we should never underestimate the power of a word to syphon energy from our reserves. As the saying goes, many will come in the name but there will only ever be one Sonus. This is like Rumours to one truth.

## **Saturday Practice —**

*First Day Mantra of the ARCH*

## The Saturn Tone (558)

Saturday is the day of **Saturn** — the tone of structure, boundary, harvest, and seal. In the ARCH, Saturn does not punish. It **stabilizes**. It is the tone that gathers what has been lived and gives it form.

For the beginner, Saturday is the natural starting point.

Not because it is heavy,  
but because it teaches **how to stand**.

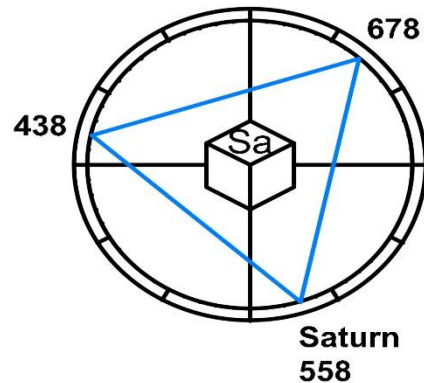

### Preparation

Find a quiet place where you can sit or stand without strain. Let the spine be upright but relaxed. Hands may rest naturally.

Close the eyes or soften the gaze.

Do not seek silence.  
Seek **presence**.

### Step 1 — Breath

Begin with the breath alone.

Inhale slowly through the nose.  
Exhale gently through pursed lips.

Do not count.  
Do not control.

Simply allow the breath to become smooth and even.

Let the body settle into its own rhythm.

Stay here for a minute or two, until the mind feels less scattered and the breath feels continuous.

### Step 2 — OM 414 (The Carrier)

When the breath has settled, begin to chant **OM 414**.

The chant may be voiced softly or silently, but let it ride the breath:

Inhale —

Exhale: **Ah Oooh Uuum.....**

Do not rush the numbers.

Let them stretch naturally within the OM.

This tone is not effort.

It is **givenness**.

Allow OM 414 to gather the field.

Feel it settle through chest, throat, and head.

Remain with OM 414 for **two to five minutes**, or until the mind feels centred and the inner space feels unified.

There is no exact time.

Wait for the sense of *arrival*.

### **Step 3 — Saturn 558 (Foot Seal)**

When OM 414 feels stable, gently introduce the Saturn tone:

**Five-five-eight.**

Do not drop OM.

Let 558 arise **within** the field OM has created.

You may alternate softly:

OM 414...

558...

OM 414...

558...

Or, if it feels natural, allow them to blend:

**OM... five-five-eight...**

Saturn's tone may feel heavier, deeper, or more grounding. Some feel it in the belly or lower spine. Some feel a quiet pressure or stillness.

Do not analyze.

Saturn's work is not to lift.

It is to **settle and seal**.

Continue with Saturn 558 for **two to five minutes**, always resting within the carrier of OM.

### **Step 4 — Rest**

When the chant completes, stop all sound.

Remain seated in silence for a short time.

Feel the body.

Feel the breath.

Feel the field.

Do not judge what is present.

This rest is part of the practice.

### **Closing**

Before returning to activity, take one slow breath and quietly acknowledge:

*The field is set.*

Then open the eyes and continue your day.

### **What Saturday Teaches**

- how to arrive,
- how to gather,
- how to stand within structure,
- how to let the field seal.

Saturn Sonus works quietly.

It builds the ground on which all other tones will later move.

### **A Simple Guidance**

Do this practice once on Saturday.

Do not repeat it through the day.

Do not force length.

ARCH practice grows by **regular routine placement**, not intensity.

OM gathers.  
Saturn seals.

**Note:** Foot Seal = 558

The significance of the Foot Seal is to do with the foot path from the Human rights to Adam's Peak where the Adams Foot print is sealed.

---

## The Primacy of Sonus/Sound: Key Value 438

Within this framework, the value 438 corresponds to "Sound," and this value can be seen in trine with the Saturn 558hz also as discover it is found polar opposite to Mercury or Sol-Om-On, on Wednesday. It is also the value of the word kingdom, stone, children, or heritage. Each of these concepts finds its place within the ARCH, serving as essential keystones in the structure. From this perspective, sound precedes the word; it exists before language forms mental stereotypes that can confine or define energy. This process of naming or assigning words can have either constructive or limiting consequences. However, by recognizing that sound is inherently pure, expansive and untainted, it becomes neither good nor bad. Instead, sound exists simply as a state of presence, the opening at the "gate" free from judgement and the burdensome qualities that words often mnemonically carry. So here again we say our motive is to strip the words away until we begin to see that there is only Om to let words become noise, and the sound be it, I am, that I am pure and simple.

Visualizing and drawing out the diagram is helpful

## Chemical bridges of Gender and Sound

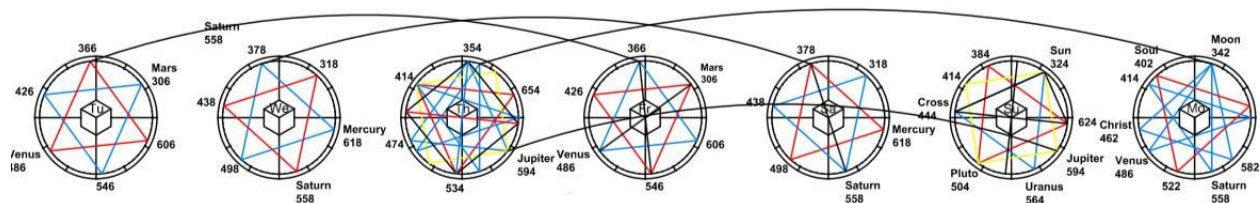

Throughout the development of this work life seemed to put me through a wine press of sorts. Pressures imposed from and on all levels of living combined with my pure desire to live and to know God, I always kept my focus on the deep knowing that there were purpose and method behind all of the seeming chaos in life. I never lost this preserved coherent Gem – Stone within my heart.

With a subconscious code breaker much like an ice breaker that cruised through the night breaking a path forward through a thick arctic ice, by the balance of dawn, I was sometimes awakening to a clear path of direction.

Such as on the morning, I awoke from a dream where a little Gnome greeted me at the base of a very steep limestone mountain. The little Gnome travelling with a smaller curious companion figure. The Gnome carried a Bushel of equal measure sticks. In the dream I had come to a steep slope that my vehicle could not travel up and over. In other words, I was at a standstill in life where it seemed I could not overcome the mountain that towered above me. The Gnome was of a serious nature with no time to stop for idle conversation. He instructed me firm and simple as he handed me six sticks of equal measure from his bushel. He said, "Arrange these to find the chemicals" I awoke from the dream with clear and concise instructions of givenness.

It was very simple, I arranged six equal pitch measures in a perfect circle to lay out a hexagram, the binding of two triangles one feminine one masculine, bridging a chemical bond of love. Let us break down the signature value of chemical according to the ancient system of base 6 gematria.

Chemical = 324

Gnome = 324

Sun = 324

Love = 324

From the temperament of 324hz or degrees I placed my stick of measure. From one end to the next spanning 120 degrees we locate the temperament chemical of 444hz. As we travel then by another stick we complete a trinity at 564hz. Then we invert the same tri order to mate the equal and opposite to the love or Sun, Gnome principle. From there we find polar opposite in temperament the value of 504hz or the signature value of Pluto. Seeing them in polar opposite made so much sense that they both signify or signal healthy bonds or unhealthy attachments. At this point we have discovered a breakthrough in chemical signatures that are sticking, literally and figuratively.

These Chemicals are guiding and leading us by pitch or will,

Sound = 438

Chemicals = 438

Coherence is showing the sound of chemicals in the signature frequencies as we place our Gematria of base 6 sticks around the ra-dial temperaments.

The Sun of Sunday returning as a state of rest for the rest of the days. The order of this becomes even more stunning as we go further into the chemistry of word.

Sunday = 504

Pluto = 504

To be stuck or to rest is the question of transmutation. Sometimes in life it can seem we are unbearably stuck. But it can prove that the stick point of chemical bond can show us we need to breathe and take a healthy rest period.

Ironically so, in this way rest can seem a sense of release as opposed to the unhealthy feeling of being stuck and overcome by a mountain.

Sun = breath

Sun = health

At this point we are not stuck; we are taking a rest to re assemble structural coherence within the monad of a time space stratus field of looping consciousness.



Monday

Tuesday

Wednesday

Thursday

Friday

Saturday

Sunday

## **The Stratus Field of Mind in Time and Space**

At a certain depth of observation, consciousness no longer appears as a stream. It reveals itself as a field — layered, dense, and quietly ordered — more like stacked stratus clouds than a flowing river. I have come to call this the **Stratus Field of Mind**.

Experience itself insists on this structure. Like earthworms of the strata, memories, emotions, and dreams tunnel feedback loops — food for thought, nourishment for the field. Patterns seek to fit and complete.

The work of the strata field undulates — rising and falling, condensing and redistributing.

The mind arranges itself as layered, flat discs — planes of inertia where experience settles and holds harmonic form.

The stack is vertical. It is not we who move through time, but time that rises, passes, and moves on. We stand within the field as moments come up, go out, and, at times, reoccur — returning through the wormholes of the strata.

## **Layered Consciousness**

The human mind organizes itself into stacked fields of stored resonance. Each layer carries compressed traces of lived experience — habits of thought, emotional tones, words once spoken or heard, identities once worn. These are not stored as stories, but as **harmonic strata**.

Just as geological layers hold the history of the Earth, these inner strata hold the history of a life.

Lower layers are denser, heavier with survival memory and unresolved loops.  
Upper layers are lighter, clearer, more spacious.

All of them coexist in looping feedback.

This is why a single word can drop us into childhood.  
Why an old grief can return untouched by years.  
Why insight can feel like suddenly rising.

We do not merely think through time.  
We circulate through **layers**.

## **The Looping Field**

Within the stratus field, consciousness moves in loops.

Thought shapes emotion.  
Emotion shapes breath and body.  
Body shapes word.  
Word reshapes thought.

And the loop completes itself.

Each loop leaves a resonant trace. Repeated loops compress into layers. Over time, identity itself becomes stratified — a stack of patterned returns.

This is not a flaw of mind.  
It is its architecture.

## **The Body as Instrument**

The body mirrors this design.

In the inner ear, stacked calcite crystals align us to gravity.  
In the pineal region, crystalline structures accumulate in rhythm.  
In the spine, fluid tides circulate in harmonic cycles.

The body is already a **stratified resonant instrument**.

The mind follows the same law.

The stratus field is not separate from the body — it is the psychological expression of the same coherent form.

## **Vertical Time**

In this field, time is no longer only horizontal.

We move forward in days and years, yet inwardly we move **up and down** through layers of stored resonance. Dreams descend. Insight rises. Trauma pulls downward. Coherence lifts upward.

Time becomes depth.

Some moments feel ancient.  
Some feel timeless.  
Some feel like rising into light.

We are not only travelling through time.  
We are travelling through **the field**.

## The ARCH of Coherence

This is where the **ARCH system** finds its natural place.

ARCH does not impose meaning.

It reveals structure.

In this field, **words are keystones**. Each true word, when spoken or held in coherence, behaves like an architectural stone in an arch — it does not push. It **locks** into place. It carries weight by relation. It bridges space by form.

A single keystone does nothing alone.

But when set among its companions, the arch stands.

So it is with words.

Each resonant word anchors a tone.

Each tone finds its layer.

Each layer aligns into a bridge of coherence.

ARCH words do not describe the field.

They **shape its curvature**.

They allow the looping mind to discover stable spans — passages through dense layers where return becomes clean and distortion releases.

This is not force.

It is **fit**.

## Days as Harmonic Plates

When seen through the ARCH of days, the stratus field reveals another order.

Each day occupies a **harmonic plate** within the vertical stack. As consciousness rises and falls, it touches different tonal strata — not as names of planets, but as lived psychological altitudes and degrees of spin.

Moon, Mars, Mercury, Jupiter, Venus, Saturn, Sun —  
each a layer of behaviour, memory, and response.

The operator does not escape these layers.

He learns where he stands within them.

To know the day is to know the tone.

To know the tone is to know the layer.

To know the layer is to know what loop is asking to complete.

## **ARCH as Navigational bridge**

The ARCH system becomes a grammar of **vertical navigation**.

Words, tones, and names act as keystones placed into the field. When set in coherence, they do not add energy — they introduce **structural alignment**. Dense loops lose their grip. The layer lightens. The arch forms.

The mind does not break.  
It **reorganizes**.

This is not catharsis.  
It is architecture.

The operator is not trying to escape the stratus field.  
He is learning to **walk its bridges**.

## **The Living Library**

In this way, the stratus field becomes a living library of resonance — what ancient language once called akashic, not as an outer record, but as an **inner stratified archive** of tone.

Everything lived is written into the layers.  
Not as words.  
As sound.

Yet this library is not a prison.

Because sound can retune.  
Loops can open.  
Layers can breathe.

## **Completion, Not Escape**

The aim is not to leave the layered mind.

Not to **compete** with mind, It is to **complete** the mind.

When loops settle and layers align, the stratus field no longer feels heavy. It becomes what it was meant to be: a vertical architecture of meaning, carrying the history of a human life without distortion.

Again, not competition between layers.  
But completion.

And in that completion, consciousness reveals itself not as a line racing through time, but as a **spiral field of return** — rising, settling, and rising again — until the field itself stands clear.

---

## Interlude: The G-nome and the Strata Theatre

By now, the reader has already met the G-nome as he placed the equal measure sticks in our minds.

Not as a theory, but as a moment — standing at the base of a mountain, offering six sticks of equal measure with a single instruction: *Arrange these to find the chemicals.*

What once seemed like a curious dream can now be seen as something more precise:

### A **demonstration.**

The mountain was not only a trial of life.  
It was a dense stratum of mind — a place where forward motion collapses and the loop can no longer rise.

And there, at that depth, the G-nome appeared.

Not to rescue.  
But to introduce **measure.**

G-nome = Sun = 324.  
The Sun made small.  
Not blazing, but guiding.

Six equal sticks.  
No explanation.  
Only form.

We now recognize them as **keystones** — the same principle the ARCH reveals in words and tones. When placed in coherence, they do not stress. They **lock** into relation, and an arch of meaning stands.

The dream did not describe bond.  
It enacted it.

Seen through the Stratus Field, the moment becomes clear: nothing moved outward. The field reorganized **within**. A dense layer was given a new carrier tone. The loop found its bridge.

And so the G-nome is no longer a character in a tale.

He is a **gesture**.

The same gesture we now see everywhere:  
in the Sun's return,  
in breath,  
in the cycle of days,  
in words falling and finding their place,  
in layers of mind lifting and settling.

The universe does not lecture.  
It gestures.

It places measure before us and says, quietly:

*Arrange these.*  
*And see.*

What has changed is not the dream.

What has changed is the eye that now reads it.

---



## Saturday Meditation — Mantra Initiation Continued

Coming to the gate of this work, beginning at the mnemonic of **558**, This is where we return, reorganize, and rediscover our own **Stratus Field of Mind**.

On Saturday, the sixth day, we arrive at a period of **saturation**. Imagine a six-sided cube filled and brought to closure, as we are now faced equally by the six days passed. Through the structural faces of time and space, we stand ready to turn over the soul's store to the day of rest that follows.

Sunday will become a contemplative period — a day of breath only.  
A Day of holding energy at rest before words, in silent meditation.

But before we enter Sunday at the midnight threshold, a family reunion of sorts awaits us with the old Saturn name, where familiarity dissolves the safe like salt in water. The structured cubic stereotype that has carried our heritage — our kingdoms, even our children — is a sound now entering a new generation as **Givenness**.

The **558 Hz OM** is like the first raindrop felt upon the face, when the scent of coming rain turns into a downpour. So too does the mantra pour from the gates of your own Stratus Field of Mind. Here we stand beneath that water, as the **Patre of patterns** breaks into dissolution, preparing the fruits of harvest for the wine of Sunday's matrimonial table — your own wedding feast.

Mantra = **402**  
Water = **402**  
Soul = **402**  
Work = **402**

The chanting of **558 Hz** in contemplative union with one's own soul can become a total dissolution into the **G.O.D.** — the *Generative Operative Dial* — the totality of fields within the field, without boundary.

From **0°**, we began at Aries. Passing then **198°**, we come to the gate — the name at **18° Libra**. And from this very degree, if we complete the full circle of **360°**, we compass again to the name and degree of **558**.

Gate = **198**  
Name = **198**  
Magic = **198**  
Seed = **198**

Here we see another layer of the famed mnemonic harvest of Saturn:  
in the seventh sign, **Libra**, at **18°**, valued at **558**.

Harvest = **558**  
Seventh = **558**  
Saturn = **558**  
Gate Keeper = **558**

---

Now we begin to find our familiarity within the strata of sound that layer our long and forgotten heritage. We are grateful to the mnemonic names that held in trust the value of what seemed to be taken from us. Yet in truth, the names written in heaven became fallen phantoms of obscurity, and our signature frequency of **Giveness** was forgotten.

Now, through a second turn of the dial — compassing us back to the temperaments of **Sonus**, of sound — we are granted our passport to return and swim again in the pool of the **Patre** using the Long Golden Key of givenness or signature frequency

As Saturday comes to pass, we cross a bridge at midnight into Sunday. If you feel inclined, you may usher the mantra — or your own soul — across this bridge by chanting **558 Hz** as you approach it. And as time crosses the midnight threshold, shift your voice and tone into **414 Hz**.

This midnight mantra marks the illumination of the souls bridge and passage —  
the lighting of your footpath of light, to go forward without fear.

---



## Beginning weekly practice stays in step with 558hz

As we continue our journey, the beginning daily practice stays with the 558 Hz and 414 Hz mantra tones, maintained across an entire week traversing the stratus field ARCH of days. Each morning at sunrise, we begin with a set sequence—breathing in, chanting Om at 414 Hz, and blending seamlessly into the Om chant at 558 Hz. This progression across the arch of the week allows the tones to resonate and touch the points of other arch tones, creating pathways for subsequent tones to follow once the foundational system is set.

By observing the geometric connections within the ARCH, the harmonic relationships between all tones become visible. As these pathways of light are opened, our awareness starts to shift in new

directions. The ongoing practice of sound construction is reflected in the evolving physiology of our brains. Each day brings the opportunity to observe new tones and their structural placement, though we are asked to refrain from chanting them until the 414 Hz and 558 Hz tones have fully established the new routes. This approach mirrors the author's own experience, where the unfolding of succession occurred naturally through dreams, without external instruction, ensuring that each new tone was revealed only when the time was right

---

## Sunday Breath, Silence, and Contemplation — Introducing ARCH Journalling

Sunday practice is held for breath, silence, and contemplation. I sometimes light a candle, but always begin with a very good quality coffee and my ARCH journal.

My ARCH journal is where I draft the day's geometrical aspects as a visual guide — a contemplative yantra, as some traditions would call it.

I use a regular circular glass to trace a circle on a blank page. My first operation is to divide the circle in half vertically, then horizontally, showing four quarter sections. I then divide each quarter by three, so that the circle holds twelve equal divisions. This reflects the zodiac above and within.

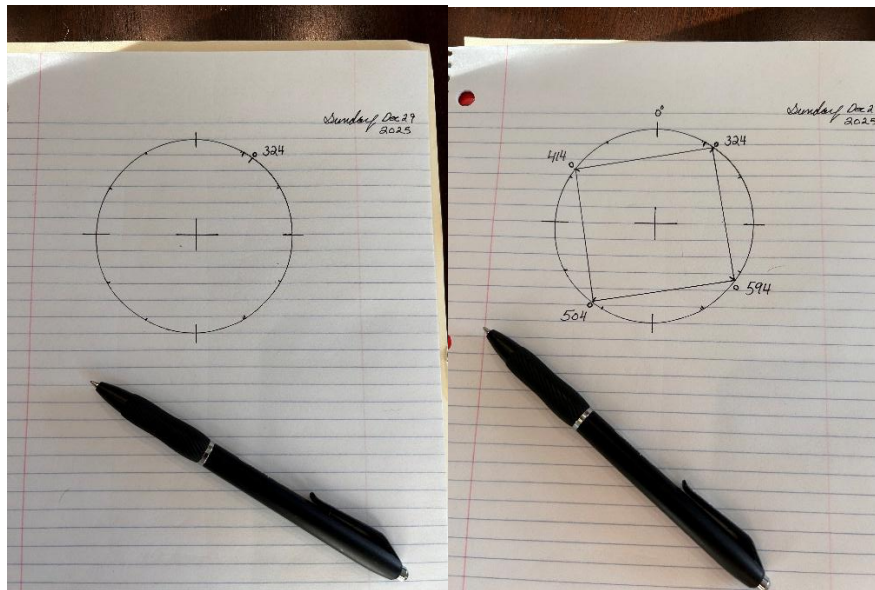

The circle represents the all-encompassing mind, throughout and within time and space.

I begin by placing a small location dot at the point where the Sun Sonus **324** is set. By default orientation, **0° or 360°** is at the top midpoint of the circle.

From 324, I draw a square inside the circle.

By stepping outward **90 degrees** at a time from 324, I land at:

- 414,
  - then 504,
  - then 594,
- and finally return to 324.

This completes a harmonic square of rights.

Harmonic = 486

Square = 486

Rights = 486

**This square stands within the circle as a quiet structure of coherence, held in breath and silence.**

**Now, the *I am that I am* is silent, still, and held in givenness.**

Reflecting back to the dream of **TE**, I find myself again working within a flat field of tension, pulled in different directions. I followed the voice of a wise, authoritative woman calling from one gate. There I was given **TE** and asked to carry it across the field to another gate, where an angry woman waited.

Two women at two gates.

One giving. One receiving.

One loving. One Hating

Through my work within the field, an exchange takes place — a living **yin and yang**. And I, as the soul underlying these operations, become the **letter carrier**. I do not own the note or the tone; I simply bear it from one side to the other, allowing the field itself to be modulated through the act.

In contemplation practice, I build my gematria vocabulary by referencing the key symbols and words that rise into conscious awareness. Now, as the **square within the circle** has triggered the dream of **TE**, I am back in the green field, working around a black hole — a **square black hole**. My thoughts are **ARCHing** into coherent frequencies.

The hole becomes a question in my mind.

The food of my thought.

The ground of my stomach.

The table a plate, serving the word in harmonic order of givenness.

Mind = 240

Akash = 240

Hole = 240

Table = 240

Food = 240

Plate = **324**  
Love = **324**  
Thought = **594**

Square Hole = **726**  
Harmonic Mind = **726**  
South Node = **726**

From this field, bridges of number, sound, and light come forward — **ARCH bridges** of number and sound spanning from one corner to the next.

On the Sunday of silent contemplation, the day settles into a deep state of coherent rest. As time comes up and goes out, I learn to embrace the **ARCH** of **Sol–Om–On** in contemplation.

The temple of my mind is framed as an **ARCH** —  
a vessel of vessels,  
a wavelength of light,  
a light of lights,  
a fire of fire,  
a boat of boats.

Like the **vesica piscis**, a bladder of fish,  
Fish like the bladder that holds them,  
a basket of baskets,  
a mind of minds.

It seems that within the whole, a chain of command is at work — one in which **light is given to dark**.

In the Sunday square we see this clearly. The **Sun** stands equal and opposite to the dark **504 Pluto**, and the **Knight 414** stands equal and opposite to **594 Thought, Jupiter**.

The square of Sunday becomes the **Harmonic Rights**:

Sun = **324**  
Pluto = **504**  
Black Hole / Knight = **414**  
Jupiter / Thought = **594**

Here the square reveals good form — coherent structure — a living balance where each corner answers another. In the morning meditation of Sunday, this geometry settles the field into order. Breath becomes even. The chain of command resolves into peaceful **Givenness** at rest.

---

**Sunday Closing Meditation**

Sunday is **Sol**.  
 Monday is **Om-On**.

### PM Meditation of Sunday

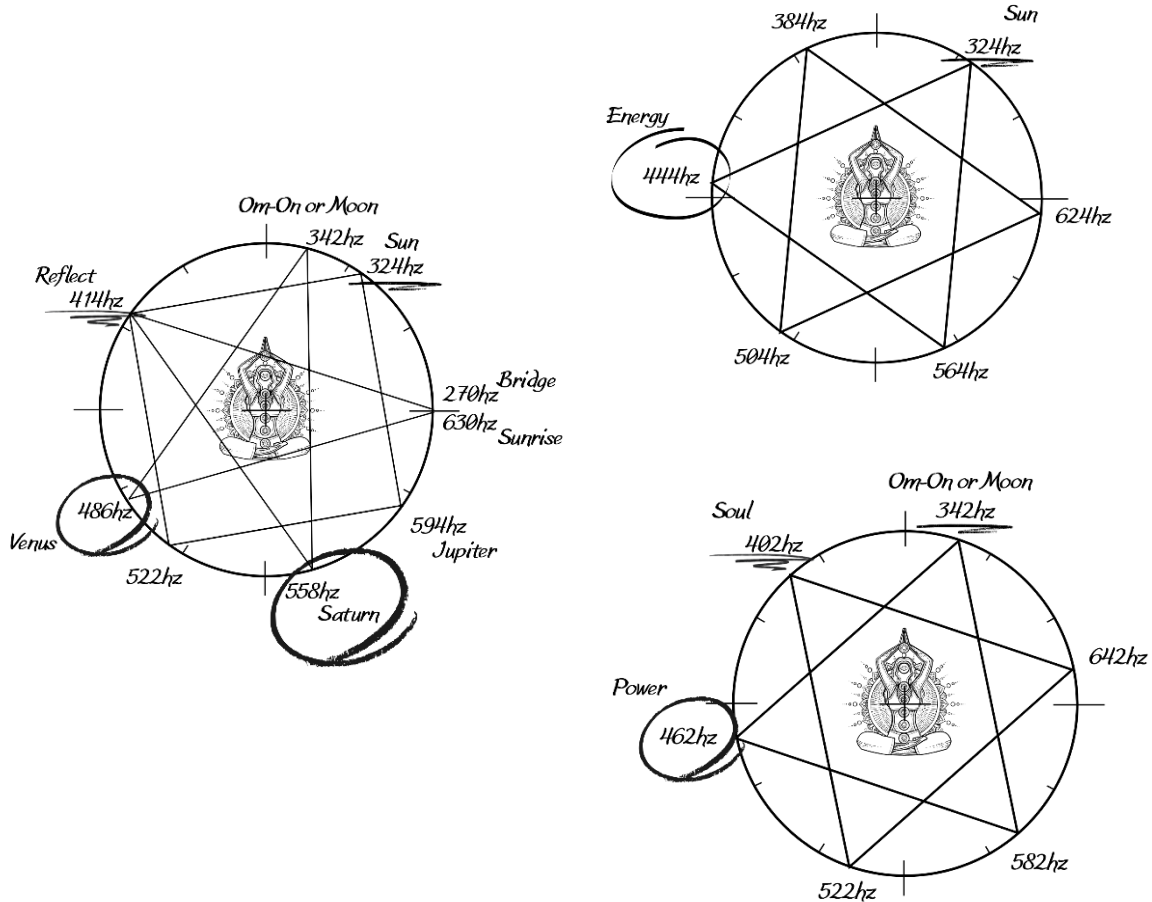

We see the ARCH mnemonic points and angles reveal a round table of mind. A table of mind pushes an unmistakable face through a silver plate of our conscious vision as our practice builds memory in strata layers as time passes on.

We see the Sun at the table of rest in equilateral trine with the electric Uranus **564** and the element energy **444**. And we see the cold fusion of Pluto **504** interfaced with **384** barium and **624** thorium. And from the square of the Sun, we see the **414** holding the seventy-two sequential path to Saturn **558**, the Moon **342**, Venus **486**, return to the sunrise **630** at the **0° of Capricorn**. And from the heads of state we see further relation, such as Mercury holding fusion trine with Saturn. We can see the pentagram of the Sun yielding oxygen at **540 degrees** and the pentagram of Pluto yielding hydrogen **576**. And so it is we see the harmonics of heaven, and we hear the angles sing, where the dots connect a new kind of song.

The stratus fields are layers from dense to subtle, layers upon layers of information. In these layers exist forms that are informed by resonance. A flea, frog, or pig exists in the strata's densities as the corresponding field layer feeds its form back to the source projector.

The human form exists the same as a holographic mirror or sensible reasoning mind in its density according to its sensing mind, mirroring its father or its Patre of Patterns.

It seems to me that the human form can free or elevate himself in successive, more subtle fields through his heart and mind balancing. It seems that the more the heart and mind can tune into the ARCH Givenness found in coherence of meditation, breath, and contemplation, the higher in state of quality the being can be experienced. That while the body is stuck in the dense field layer of what we call matter; the mind and heart can facilitate the soul's differentiation from this world.

This is to say that we have the keys to unlock the gates that hold us on the hot desert sand of a world under pressure of the serpent binding us in space and time. And that the mnemonic names above, held in the heavens, saturated with our forefathers' struggle and pain fixed to this world damned from God, we are but a breath away from the loosening and unbinding by the power of soul himself, being the authoritative serpent bearer.

Serpent bearer **876**

Long golden key **876**

## Soul as Serpent Bearer

### The Nature of Soul's Power

It is often said that the soul is all-powerful, and while this holds true, it does not exempt us from facing heavy and painful burdens throughout life. It can be frustrating to hear talk of love, light, and the secrets of attraction, especially when those who speak of such things encounter difficulties that even their positive mindset cannot overcome. The reality is that no one is immune to the challenges and struggles that arise; adversity touches everyone regardless of their attitude or supposed powers.

When life brings its inevitable wind and rain, they fall upon us all indiscriminately. Yet, what we must face will be met with resilience: our armour is strengthened, becoming more substantial and capable of greater deflection. The soul's growth depends on encountering resistance, for only through bearing greater energies and breaking new pathways does awareness expand. If the soul

is likened to grapes on the vine, then it must be pressed to become wine; transformation occurs through the process of refinement.

### The Gates of Givenness and Routine

The soul must navigate its gates of givenness, where knowing becomes a natural part of doing. Through this work, it is revealed that the state and quality of being is determined by frequency and routine operations, which together form an expanded operating system. This system is not limited only by the power of words, but by the information that gives words their meaning and impact.

The Sonus, or sound, represents the pure seat of the soul—the essence of "I am that I am." Words are merely phantoms of the opera, while Sonus is the true director of life's play and theatre. However, these poetic notions gain substance only when the layers of the mind's stratus field are formed through routine, allowing the heart to sing each tone in its own hour by its own givenness. This is the point where practice becomes the self's gift, even in a troubled world.

## Monday's Practice — Beginning Stages

At this early stage, we work only with the two foundational tones: **414 Hz** and **558 Hz**.

This routine will remain unchanged until we return to Sunday. At that point, we will begin the more advanced morning binaural beat meditations, working with the power squares. For now, precision and restraint are essential.

Before complexity, we lay the foundational route through the field.

Imagine yourself as one of the original explorers who first cut passages through the Rocky Mountains—long before paved highways ran from coast to coast. Or imagine the first communication line laid across the ocean floor, quietly linking two distant worlds. These were not acts of speed or force, but of patience, alignment, and commitment to continuity.

Our inner landscape reflects this same reality—yet it is far greater in scale and potential than any external terrain. To bridge these inner distances, to establish stable crossings through the ARCH bridges of the heart and the mind's stratus field, is one of the great frontiers of the conscious human being.

This work begins there—slowly, deliberately—by laying the first paths that future movement will work upon.

will work upon.

## Monday Sunrise Practice: Where Energy Becomes Power

Monday morning sunrise practice marks the moment where energy meets power. After the rest-state of Sunday—when the powers around the table sit in stillness—the Sun releases its stored resonance into the new cycle. That release enters Monday through the threshold of the Mouth, the organ of resistance and form.

Energy moves freely.

Power gives energy shape.

Power arises through resistance.

The mouth is the first instrument of this shaping. Through opening, closing, tension, and measured release, stored potential becomes breath, tone, and word. This is why power (462) corresponds harmonically with mouth (462) in the ARCH system. The numbers reveal the relationship: resistance gathers energy into form, and form allows energy to act.

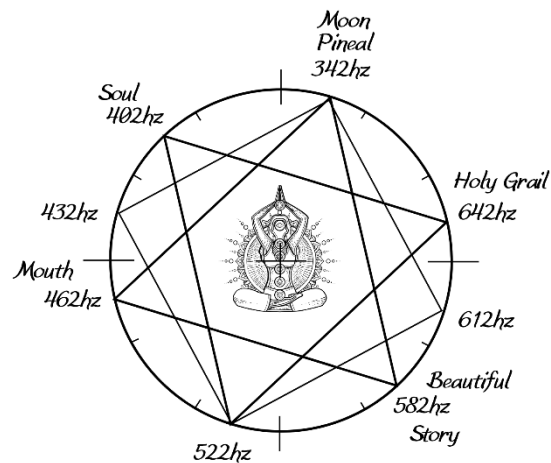

Monday is the day of holding, forming, and releasing with measure.

Om-On: The Cross-Dimensional Switch

The transition from Sunday to Monday is governed by Om-On, the harmonic threshold where the Sun's energy discharges into the shaping power of the new week. Om-On (or Moon, 342) is the cross-dimensional switch—the moment where resonance becomes form, where the last supper of Sunday's ARCH mnemonic union releases into Monday's generative field.

Becoming conscious of this shaping power—especially in the mouth's ability to modulate sound through resistance—is the next level of knowing. It is the beginning of conscious participation in the architecture of tone.

Energetic Structural Harmonics (ESH)

In the ARCH dynamics, ESH (Energetic Structural Harmonics) describes the generative tension and release between days, planets, and geometric forms. These tensions are symbolized as they are structural. They arise from the polarized fields that govern the stratus-layered continuum of consciousness.

Each day initiates a harmonic movement in its opposite across the week:

- Monday initiates Thursday
- Tuesday initiates Friday



Though these principles may sound technical at first, they are as natural as the birds and the bees. The challenge is not the system itself—it is our unfamiliarity with interpreting sexual, generative, and harmonic functions in geometric frequencies. We have not yet learned to read the architecture of our own operating system in this unique way.

But as human consciousness evolves, and as science begins to explore the deeper structures of life's information, these patterns will evidently become visible again. It's just a matter of time beginning with such explorative works such as this.

## Tuesday Morning Beginning Practices

As the week progresses, we stay with the foundational tones 414hz and 558hz. Start with a few minutes of breath regulation always before chanting. In my personal experience breath work is not a rigid discipline, it seems the body heart and mind regulate time naturally according to ones own physical and mental needs. As general rule of thumb, a longer exhale then inhale through pursed lips will slow and stabilize the heart and polyvagal.

## Tuesday Yantra Practice

Drawing geometric yantras helps orient and familiarize conscious awareness with subconscious mandala substrates. This practice also brings to the fore the structural aspects of the work that reveal **regenerative coupling and pairing**.

If you notice in this energy diagram, **Mars and Venus appear as polar opposites** in the arrangement, positioned directly across from one another through their ARCH name gematria values. This polarity is not antagonistic. It forms a regenerative axis where directed force and coherent Comb binding remain in dynamic relationship.

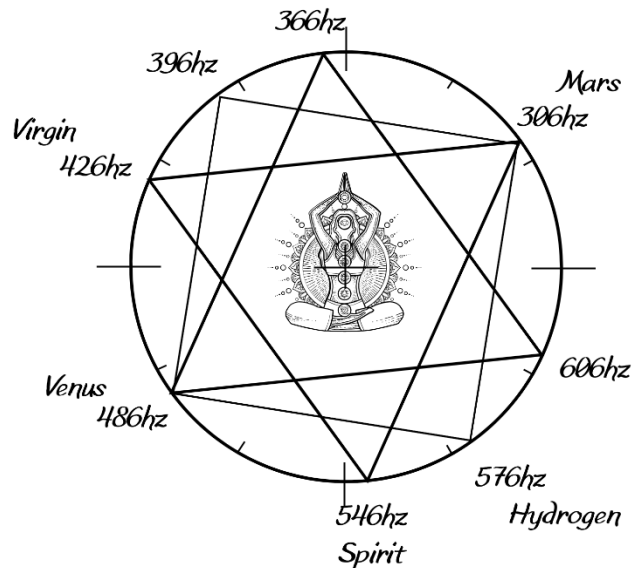

Mars, as the Tuesday gate, represents activation and outward expenditure. Venus, as its polar counterpart, represents cohesion, return, and integration. When these two are held in geometric opposition, action does not deplete the system. Instead, energy is circulated across the field, allowing momentum without exhaustion.

This yantra demonstrates that Tuesday's function is not to discharge force blindly, but to **cross the field through resistance**, establishing pathways that will later be gathered and sealed. The lines do not terminate; they return, completing the circuit and maintaining coherence.

On the Friday coming, this same polarity resolves through Venus, where the energy set into motion on Tuesday is received, softened, and brought back into balance. In this way, the day chain operates as a regenerative sequence rather than a linear expenditure of force.

## Wednesday Morning Beginning Practices

### Binaural Beat Introduction — Structural Drift Awareness

Still walking the **414 Hz and 558 Hz footpath of light**, we continue with breath-balancing while seated comfortably. Today introduces the **binaural beat method** of tonal practice. I have found this method effective in several ways, but most importantly it develops **conscious awareness of structural drift**.

As we begin to reflect on **relative pitch** and the ability to hold that pitch, a return signal naturally arises from its point of origin. This return is not imagined; it is structural. When viewed through the Yantra, the chording of angles reveals how the circuit completes itself, closing the polygon through reflection rather than force.

As we voice a tone, the operator systems register **tonal anchor points**, then distribute reflections outward through a **geospatial, geometric circuitry**. This is not unlike a game of pool. Before making a shot, focus and stillness are required to anticipate the angle of deflection and return. In this practice, the voice functions as both cue and ball, and the tonal field becomes the table upon which reflection occurs.

In this sense, we may note the following ARCH correspondences:

- *Pool = Star = 348 = Father*
- *Table = Mind = 240*
- *Game = God = 156*

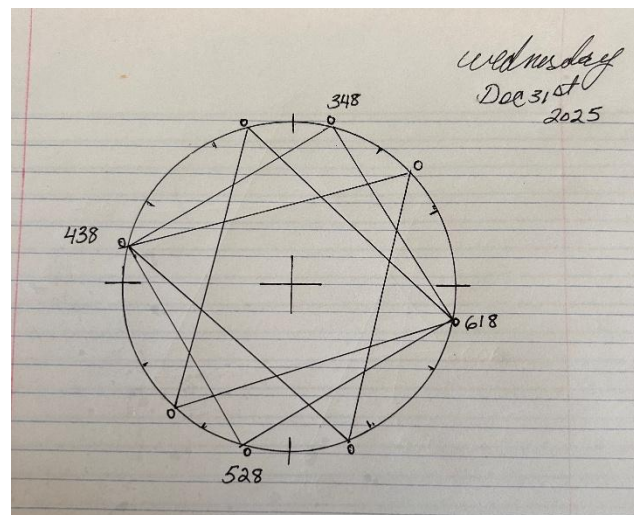

Here, “pool table” may be understood as **Star Mind**, and “game of pool” as **Generating Operating Dial of the Zodiac**. These correspondences illustrate coherence within the ARCH mnemonics, but they are noted only to orient understanding, not to distract from practice.

Returning to the method:

In binaural tonal beat practice, one tone is **held by the voice** while another tone is **introduced externally** through a tone generator. The external tone creates an attractor that attempts to pull the voice off course. The task is not resistance, but **remaining on point** — maintaining orientation while interference is present.

This practice builds the capacity to recognize drift without reacting to it. When the pitch of angular tonal distribution can be held steadily, a broader perception of the reflective field emerges. The practitioner begins to sense the full geometry of the **zodiac pool table** or **star mind**, where motion, reflection, and return occur continuously without loss.

This is the function of Wednesday:  
to mediate signals, above and below  
to redistribute and balance pressure,  
and to maintain true north.

**Canada Goose and serpents from the Red River dream could represent Binaural beating without drift.**



You may remember this image from the opening dream of the book, where two cobras came out of the Red River and latched onto the wings of a goose as it flew north. Somewhere within these pages, the reader may also begin to take flight — maintaining one's own path toward true north without drift.

Dreams are the **Patre of patterns**, revealing arrays of symbols that latch onto the mind at rest. As the dreamer flies in sleep, freed from the ground and its constraints, submerged currents begin to rise. Feminine vibrations from the emotional rivers below reach upward, seeking contact with the mind's operating system.

### Thursday morning beginning practice starts with Yantra orientation

The eyes are the voice to the inner sun at the seat of the heart. The eyes can see there are no two faces but one cut or Mithra. Mithra a lawful joining of two sides made one resolution. Today as these words join to become manuscript material on the 1<sup>st</sup> day of 2026 in Osoyoos B.C Canada. Forward to this matter we cut through to one degree temperament of 414hz which is the Mithra polar opposite 594hz of

Thought or Jupiter being that it is Thursday morning. Vicariously through the union or joining of both Jupiter and Mithra equilateral triangles, we can see an agreement between the two drawing a line from 444hz to 624hz. This is the squaring of two equal opposites by the cut and cross of breath and energy.

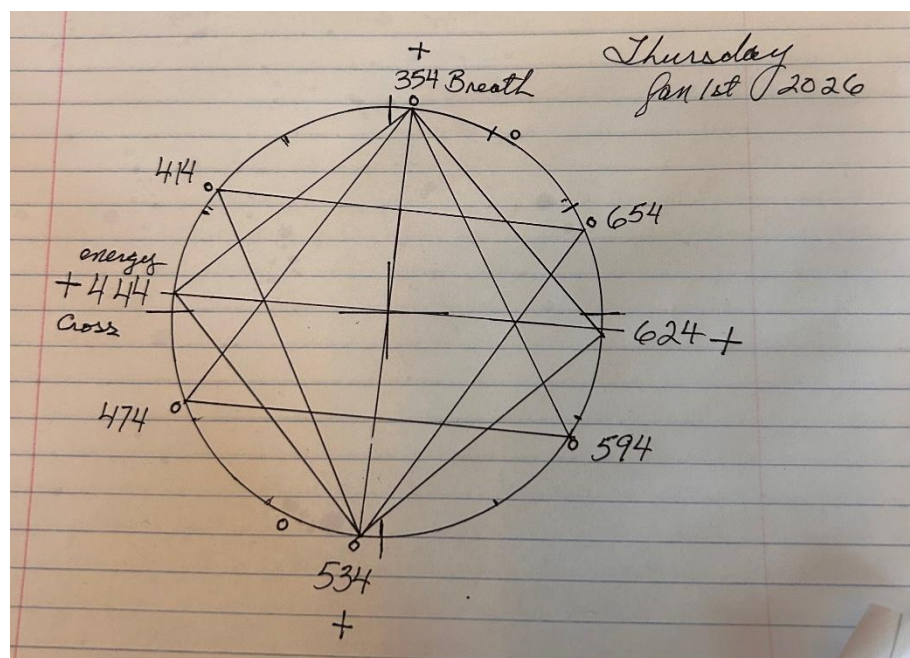

### Key Mantra Reflection

The essential teaching of this mantra is encapsulated in the phrase: “know yourself or you may think it's yours.” This insight acts as the crucible—the very cube—upon which the mantra is founded. Often, words arrive bearing the weight of names, and with them, a multitude of voices, each expressing varied perspectives or polarizing oppositions. In such a landscape, it is easy to become caught in the play of dualities, where two faces appear to be set in opposition.

However, the heart of the practice calls for recognition of true joining beyond mere polarity. Genuine agreement is not found by splitting or dividing, but rather by discovering unity—a single point of convergence. To agree authentically, there must be one degree, one decisive cut, one unified Sonus. This unity transcends opposition and re-establishes coherence at the centre of the self.

In the dream of Givenness, the woman rose—an agent of inner truth—and said: *You have nothing of this earth that is yours to give except for Givenness.* Of the self, there is only one givenness, not two sides but one. A single communion of self within the Patre of patterns—whole, intact, and protected from outer words that thrive by default on polarization and argument rather than agreement.

In litigation, profit accrues to the bar through argument, whereas mitigation requires free, reasonable, frictionless agreement. This distinction appeared again in the dream of walking across a plane with a tall man in a snakeskin jacket, speaking of honesty and debt reconciliation. At the exit of this plane of destruction hung a bag of unknown contents bearing my deceased grandfather's name, suggesting that he had left his baggage behind.

To cross a plane of tension—to cross-examine, to move across a field—while listening to the words of the man in the snakeskin jacket is to be guided toward a single gate. There, a bridge appears, divided not by his tongue but by past and present—by *I am that I am*—marking the end of one cycle and the entry into another. I approached as a child and saw a sign on the post bearing the name *Captain John Russell*: not merely a name, but a master-mariner's mark, directing the precise degree of crossing.



We do not carry our names; we pass through them. As frequency passes, as givenness passes, so do recurring signature paths repeat—systems a clean and pure child's soul crosses unadulterated. Leave the baggage of the name on the post. Go through the gate without purse or defense.

## Friday Morning Mantra Yantra Practice

### Preparing for Practice

As with every session, begin by settling into a comfortable position. Take time to focus on breath work, allowing your breathing to regulate and prepare both mind and body for the practice ahead. This initial step is essential, setting a foundation of calm and clarity before moving forward.

### Orientation and Yantra Drafting

Orientation remains central to the process. While drafting the Yantra may not appeal to everyone, it acts as a valuable tool for facilitating multi-level orientation. The Yantra provides structure, helping to layer the stratum of daily mental mnemonic recognition and anchoring practice in the present moment.

### Chanting and Tonal Work

Begin the chanting practice using the 414hz tone. Strive to match your

voice as closely as possible to this pitch. You may notice a distinct oscillation or "wobble" between your voice and the tone generator—this phenomenon is known as beating, which occurs when two tones resonate closely together. The sensation of beating can feel as though it is drawing you into the sound, enhancing focus and immersion.

### Layering Tones

While chanting at the 414hz frequency, switch the tone generator to the 558hz setting while continuing to hold the 414hz chant with your voice. This exercise is designed to build your ability to

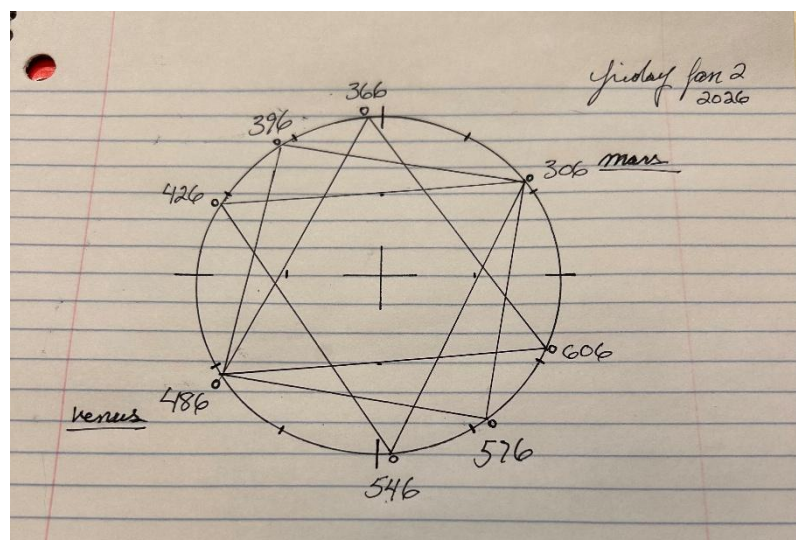

remain on course and in key. The brain naturally blends these two tones, producing a binaural beat—a unique sensation that may become increasingly enjoyable as the tones interact.

## Completing the Mantra

When you feel ready, transition your voice to chant the 558hz tone to conclude the mantra. This final shift marks the completion of the practice for Friday morning, reinforcing orientation and focus for the day ahead.

# Saturday Mantra Practice: Beginning and Completion on the Footpath

## Preparation for Practice

As with every session, begin by settling into a comfortable position. Take time to focus on breath work, allowing your breathing to regulate and prepare both mind and body for the practice ahead. This initial step is essential, setting a foundation of calm and clarity before moving forward.

## Chanting and Tonal Work

Begin the chanting practice using the 414hz tone. Strive to match your voice as closely as possible to this pitch. You may notice a distinct oscillation or "wobble" between your voice and the tone generator—this phenomenon is known as beating, which occurs when two tones resonate closely together. The sensation of beating can feel as though it is drawing you into the sound, enhancing focus and immersion.

## Layering Tones

While chanting at the 414hz frequency, switch the tone generator to the 558hz setting while continuing to hold the 414hz chant with your voice. This exercise is designed to build your ability to

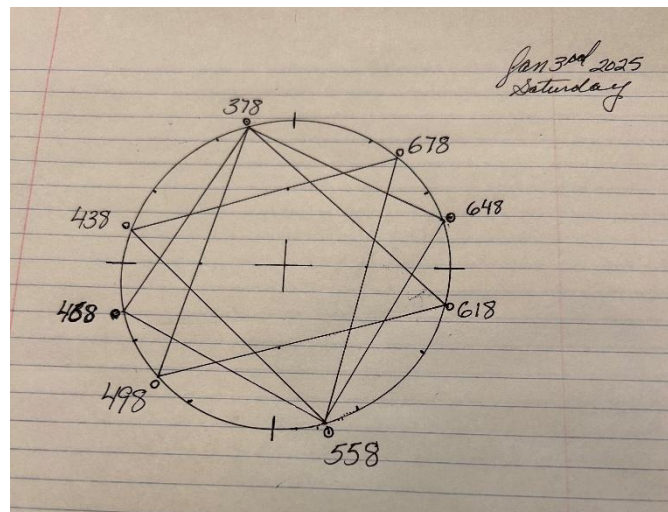

remain on course and in key. The brain naturally blends these two tones, producing a binaural beat—a unique sensation that may become increasingly enjoyable as the tones interact.

## Completing the Mantra

When you feel ready, transition your voice to chant the 558hz tone to conclude the mantra. This final shift marks the completion of the practice for Saturday morning, reinforcing orientation and focus for the day ahead.

## FootSeal and the ARCH Path

If you have made it to this destination without drift and have taken the steps along the ARCH (archetypal resonant chain harmonic). Congratulations, you may put your foot down to create your “FootSeal” on this day. Foot seal = 558

In this work, a Foot Seal is your foundational signature stamp of authorship and the right to take steps towards the path of light that is your heritage. From here, we begin using the other tones of the ARCH mnemonic day chain to build and strengthen your ESH—Energetic Structural Harmonic vessel. The ESH is a vessel of structural fire that carries us through floods and storms that may come.

## Sundays Practice

### Yantra for Silence and Contemplation

#### Correspondence Across Realities

Within this practice and study, the facets of reality correspond at every level, both in tangible and imaginative forms. Creativity—whether expressed through writing or painting in extraordinary and unconventional ways—arises from an underlying structural framework. This framework is the foundation that makes such imaginative acts possible.

#### Levels, Stages, and Narrative Simulation

All things exist appropriately within their own level of play, where each level represents a stage. Upon these stages, various sets host scripts and stories, each aligning with its corresponding narrative simulation. The distinction between what is visible and invisible is ultimately a harmonic construct of the mind.

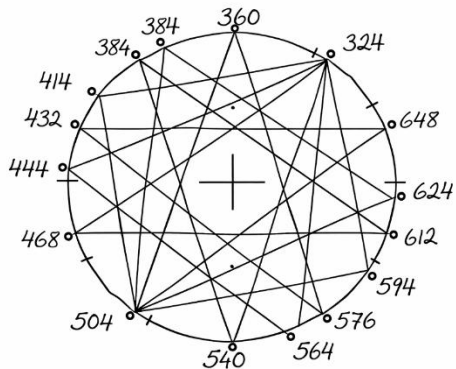

*Sunday Yantra for Silence & Contemplation*

## Unity of Experience

When we sleep, social distinctions, such as the king and the pawn, disappear as both enter the same box—the shared realm of dreams. In this state, we are immersed in the plasma pool of dream beings, underscoring the interconnectedness of all experiences.

## The Script of Harmonics

Everything appears to follow a script defined by harmonics—be it digital sound or plasma number. There is a resonance between different modes of being: digital, cosmic, and plasma, each sharing the value of 372. Similarly, number, sound, and kingdom share the value of 438. These equivalences are supported by the law of resonance, which affirms that the unseen harmonizes with the seen.

## Contemplation and the Yantra-Mantra Connection

Contemplation can occur through the yantra of the mantra. The mantra itself may be understood as “man” plus “Ra,” signifying the mind extending to the radius of its own pool. This perspective reveals that the hues surrounding us are reflections of the human standing at the centre of their own structural sound mind, reinforcing the concept of a harmonious and well-balanced mind.

As we move then further into the practice developing and strengthening layered memory of tonal coordinates we will begin to sense and recognize **our inner structural orientation system**.

## Monday Morning Mantra Practice

Begin your Monday morning by centring yourself with intentional breath work. Settle into a comfortable position and gather your materials—paper and pen—preparing for the orientation practice. This involves drawing the yantra for the morning, following the diagram provided for guidance.

The Monday mantra practice utilizes binaural chanting, starting with the tone of 342 Hz, which corresponds to the Om-on/Moon resonance. As you chant at the 342 Hz pitch, activate your tone generator to produce the next tone, 432 Hz, while continuing to vocalize at 342 Hz. Allow these two tones to merge for several chants, creating a harmonic blend in your awareness.

When you feel prepared, elevate your chanting voice to match the 432 Hz tone. At this point, you leave the binaural chord and focus your attention on the single pitch of 432 Hz. When you are ready, adjust the tone generator again, this

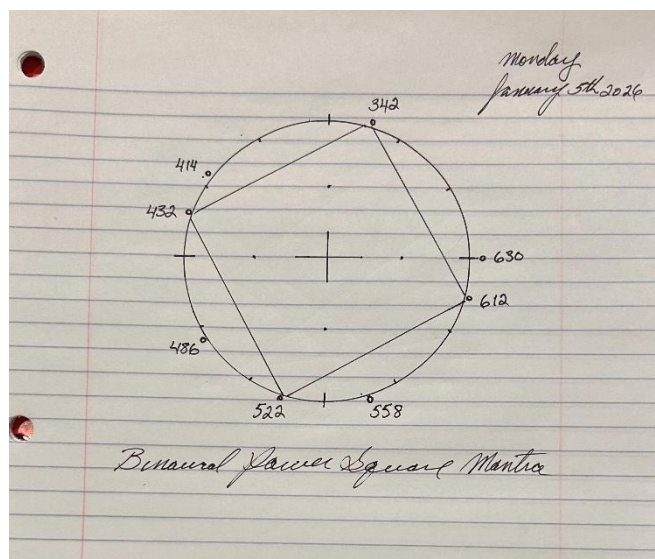

time to 522 Hz, while holding your voice in the memory of the previous 432 Hz pitch. Let the new and previous tones intermingle, blending their resonance.

Progress by switching the generator to 612 Hz. Blend your chanting voice between both the 432 Hz and 612 Hz pitches, allowing the tones to interact. When you feel ready, shift your voice fully to the relative pitch of 612 Hz. Let your voice rise and immerse itself in this tone, attuning to the subtle beating or wobble that arises. Once you are ready, turn off the tone generator and simply sit in peaceful stillness, breathing deeply for a minute or two to conclude the practice.

## Monday Evening Mantra Practice

### Purpose of the Evening Mantra

The Monday Evening Mantra serves as a process of levelling—a gentle ritual to even out the energies and experiences of the day. After a day of hard work and deep thought, this practice creates space to relax and let go, allowing the events of the day to fade and preparing to begin anew with tomorrow's sunrise.

### Preparation

Start by drawing your chosen mantra, if you wish, or use the diagram provided in this companion book. The act of drawing is optional and meant to help you settle into the practice, symbolically allowing the day to fall away as if it were a story to be continued.

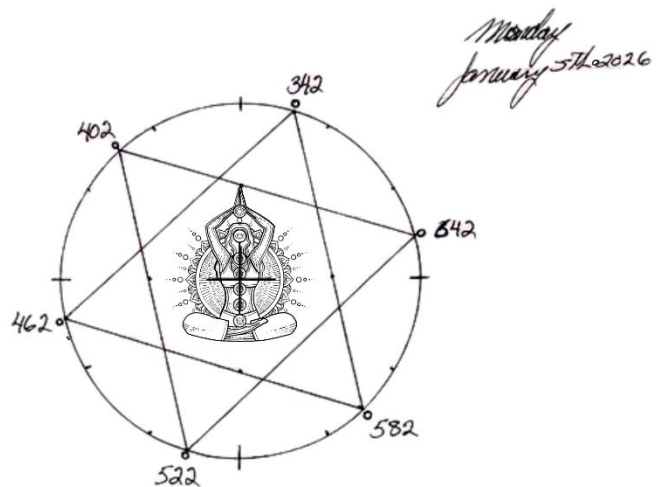

### Breath and Tone Initiation

Begin with mindful breathing, focusing on lowering tension within your nervous system. Then, initiate the practice using the 342 Hz tone. This tone sets the foundation for the binaural method that guides the rest of the evening mantra.

### Binaural Toning and Self-Centring

Using the binaural approach, move successively in a counterclockwise direction, blending the tones and attuning to their movement. This process allows your sense of self to shift gently toward the centre, guided by the harmonics rather than active effort.

Allow the tones to guide you; your role is simply to become light enough to be drawn to the centre, like a magnetic being aligning with its own north pole. This centring is the heart of the evening mantra, helping you find balance and self-alignment as the day comes to a close.

## Tuesday Morning Mantra Practice

### Settling into Routine and Preparation

As our practice becomes more routine, a sense of unity emerges within our system. We begin the morning by sitting quietly, consciously regulating our breath, and gathering the materials needed for this session. With calm intention, we draw a circle to represent the day—a symbolic gesture that marks the start of our practice.

### Understanding the Coordinates and Sonus

Through continued engagement, we develop greater awareness of the directions and coordinates associated with the mantra tones, referred to as Sonus. In our terminology, Sonus is considered the "Son" of the Patre, or Father. Gradually, we align ourselves with the inherent simplicity of this work, focusing our objective on cancelling out unnecessary noise or plasma.

Here, "noise" refers to the plasma of words attached to the Sonus values. The first step is to recognize these associations; the next is to observe the detachment of words from the primal sound, or the degree of Sonus itself. This process leads to what can be described as the alleviation of mental gravity. When Sonus is released from words, we may experience mental levitation in varying degrees. In essence, mental noise is equated with mental gravity, while mental Sonus tone corresponds to mental levitation.

### Tuesday Practice: The Method and Tone

The Tuesday mantra practice begins with the 306 Hz tone. At this stage, we make use of the binaural method by default, blending two tones—one produced with the voice and the other with a tone generator. The practice unfolds by chanting the first tone and then following, or "chasing," the tones through the dial, allowing for an intentional overlap of sounds.

This approach encourages the mind to establish mitres, or splitting averages, which ultimately draw the focus back to the central radius point, the anchored goal post of the practice.

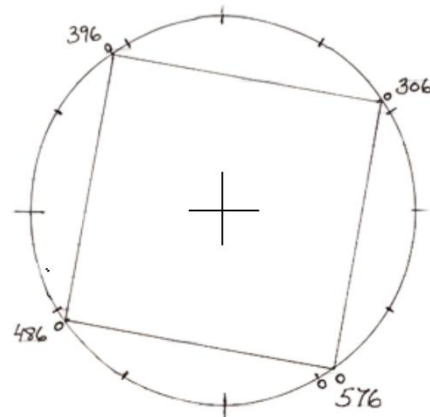

## Interlude to Mental Gravity

Mental gravity can be understood as the gravitational pull created by polarized mental systems characterized by incoherence and internal conflict. These systems often operate unconsciously, subtly drawing down our mental energy—almost like a thief in the night. The process can begin with something as simple as a single word or a passing thought linked to a trivial event. Soon after, more words and memories cluster around this moment, and an internal dialogue takes shape, spinning out in the muddy landscape of the mind. During these times, mental fatigue sets in as the inner dialogue multiplies, turning into overlapping conversations. The resulting chaos creates a downward spiral, and before long, you may feel flattened and pressured by various sources within both your mental and physical being. This stress often spills across different aspects of your state, amplifying the sense of being mentally drained.

It is precisely at this point that one has the opportunity to interrupt the ongoing internal dialogues. By momentarily breaking the frequency phase locks of negativity dominating your mental space, you can regain control. A maintenance mantra serves as a tool to regulate and recentre the polarized energy that is pulling you out of balance.

Personally, I use the hourly Chaldean tone to guide myself through such moments, and I find it to be quite effective. Is this effect due solely to the specific tone assigned to the hour? I cannot make that claim. However, I choose to reference the hourly tone because it is a routine—a scheduled pattern that has been followed for thousands of years without interruption. Whether or not this makes a measurable difference, I cannot say for certain. What I do know is that participating in a continuous and ancient sequence provides me with a sense of order. Knowing that I am joining into this ongoing pattern gives my mind a positive focus. This effect may be psychosomatic, but sometimes that is exactly what is needed: a supportive trigger to help the mind draw boundaries against the mental gravity of negative inner dialogues that can drain us when we are not vigilant.

## The Chaldean Order Sequence

The Chaldean order plays a recurring role in the practice, providing a structured sequence that guides the progression of tones and planetary associations throughout the day. This sequence is both ancient and methodical, lending a sense of continuity and tradition to the mantra work.

*Tuesday Sunrise Sequence of Chaldean order example:*

**Morning (Am):** The sunrise sequence for Tuesday begins with Mars, followed by Sun, Venus, Mercury, Moon, Saturn, Jupiter, then repeats as Mars, Sun, Venus, Mercury, and Moon. This succession establishes the foundational signature frequencies for the day, reflecting the ritual's alignment with planetary energies.

*Tuesday Sunset Sequence*

**Evening (Pm):** At sunset, the Chaldean order resumes with Saturn, Jupiter, Mars, Sun, Venus, Mercury, Moon, and continues through Saturn, Jupiter, Mars, Sun, and Venus. This evening cycle maintains the flow and rhythm established at sunrise, ensuring the practice's consistency across day and night.

### *Transition to Wednesday*

As the cycle progresses, the next day's sunrise—Wednesday—will always begin with Mercury. This ongoing rotation creates a long-standing pattern of signature frequencies for each day, reflecting the enduring nature and interest of this ancient sequence.

## Tuesday Evening Mantra Practice

The practice of the Tuesday evening mantra is designed to help bring routine, closure, and balance to the day. Begin by settling into a comfortable position, allowing yourself to relax and focus on your breath. Take a few slow, deep breaths in and exhale gently. Gather your notebook and pen to mark the boundary between the day's activities and the evening's reflective space. This ritual helps you to even the score and draw a line, signalling the transition from day to night.

As you breathe in and slowly exhale, start to draw out your points—both literally, in your notes, and figuratively, within your consciousness. Connect the dots, acknowledging that everything that is above is also below. The act of connecting these dots represents the merging of consciousness and subconsciousness, letting the day's experiences integrate fully.

Initiate the mantra sequence by beginning with the first tone at 306 Hz, then move to 366 Hz, followed by 426 Hz, 486 Hz, 546 Hz, and finally 606 Hz. Allow each tone to overlap and resonate, letting them ring out and blend naturally. As your body and mind settle into this regularized sequence, you may notice epiphanies arising and a growing awareness of interconnectedness. The inner dialogue shaped by these tones is both structural and geometric, with the centre of this dialogue holding the core of your experience.

Through tonal chanting, you are able to access and tune into the precise radius of the centre, releasing all mental gravity and achieving a state of peace and rest. This evening ritual serves as a disciplined and mindful way to conclude the day, fostering inner harmony and reflective clarity.

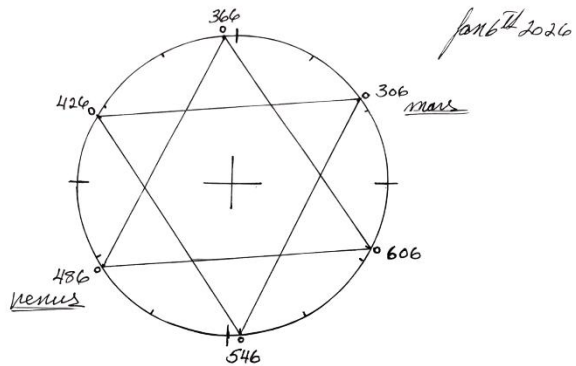

# Wednesday Morning Mantra Practice

## Establishing the Morning Routine

The Wednesday morning mantra practice begins with a focus on breath, sitting posture, and orientation. These foundational steps encourage a sense of calm and readiness, preparing the practitioner to engage fully with the ritual.

## Drawing the Square: Frequencies and Planetary Alignment

To start, mentally or physically draw out the Square, beginning from the first point at 618 Hz. This tone is associated with Mercury, the planetary ruler of Wednesday, and serves as the guiding frequency for the day. The process continues by connecting the dots counterclockwise around the twelve sections of your circle, following the sequence: 618 Hz, 348 Hz, 438 Hz, and 528 Hz. Each frequency occupies a distinct role in the morning ritual, and practitioners are invited to attach words of significance to the tones—today, the word

**dignity** is paired with the Sonus of 528 Hz, but you may choose words that resonate personally.

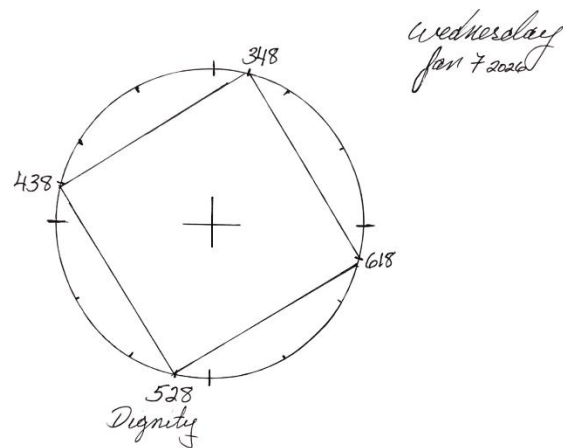

## The Binaural Method: Initiating Tones and Personal Associations

Begin with the lowest tone of 348 Hz, applying the binaural method to deepen your meditative state. This frequency is affectionately associated with "Father," grounding the practice in a sense of care and stability. Moving through the sequence, 438 Hz resonates with sound, children, kingdom, and heritage, capturing the continuity and generational aspects of the practice. The frequency 528 Hz, widely regarded in spiritual circles for its healing properties, acts as the healer of dignity within this system. Finally, 618 Hz represents a personal connection, symbolizing the name Solomon, and reinforcing the intimate nature of these sonic associations.

## The Mnemonic Power of Names and Frequencies

Names carry dynamic mnemonic potential, with their sounds functioning as harmonic cues that retrieve memories from lived experiences. This process forms within our circular monad mind and is understood as information—a circuitry of frequency confined within a circle. The technology of patterns emerges here, looping within the system of internal dialogue and shaping the contours of our consciousness.

## Pattern Recognition and Mindful Presence

Through repeated pattern recognition, the conscious mind gradually clarifies its perspective, becoming more present and attuned. This mindful approach allows for greater awareness within the "digestive system" of one's own micro mind biome, fostering inner balance and clarity at the start of the day.

## Wednesday Evening Mantra Practice

### Setting Intentions for the Evening

On Wednesday evening, the intention is to return to a state of inner peace and sobriety, fostering a sense of coherence within. The practice encourages you to be moved by the resonant frequencies of the mantra, which requires releasing any mental burdens—those thoughts and worries that weigh down the mind and increase its gravity. This act of letting go is not a conscious struggle, but rather an unconscious softening, inviting innocence and belief to guide the process. There is no demand for belief in anything grand; the aim is simply to allow your sense of being to be carried gently by the currents of sound, drawing you into the centre of your own inner circle.

### The Sequence of Tones

As the chanting begins, the practice starts with the 378 Hz tone. This tone is gradually blended with the next in sequence, 438 Hz, allowing the sounds to interweave through binaural beats. The flow continues as each following tone is introduced and mixed, culminating with the 678 Hz tone. During this progression, each frequency remains present within your subconscious, creating a continuous field of resonance as you move through the cycle.

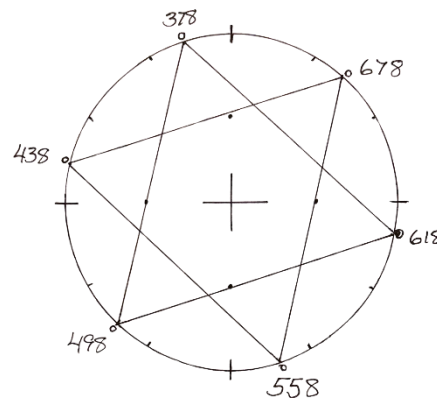

### Achieving a Balanced Centre

By the time you reach the final tone, your mind has travelled through a complete field of sound. The tones you have chanted linger in your subconscious memory, and your mind instinctively sorts and arranges the angles and pitches, forming a hidden mandala within—one that is not consciously perceived as a tangible image, but is felt through a growing sense of peace and balance. This inner equilibrium signals that you have found your centre. When you feel balanced, you are truly centred.

## Thursday Morning Mantra Practice

### Breath Regulation and Orientation

Thursday morning practice commences in a familiar manner, mirroring the routine established on other mornings. The session begins with breath regulation, aligning the mind and body, and establishing a sense of orientation. However, there is one main difference that defines Thursday's approach.

### The Origin of the Morning Square

Unlike other days, the morning square on Thursday does not start from the Jupiter Sonus point. Instead, it originates from the Sonus point associated with the Breathe frequency at 354 Hz, which is situated 120 degrees from the Jupiter Sonus point at 594 Hz. By constructing the square from the Breathe point, a connection is made with the Cross value of 444 and with the 534 Hz value, which is also 120 degrees from the 414 Hz point. This process creates a line of agreement that forms the square in relation to both the Jupiter and 414 Hz points.

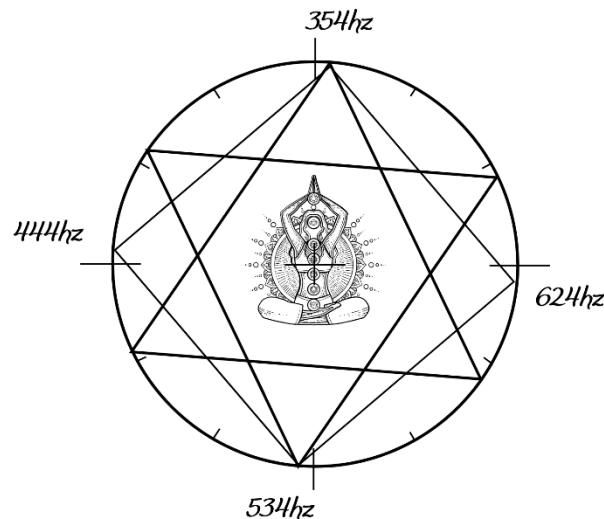

### The Platonic Space Square as a Bridge

This unique arrangement forms what is described as a platonic space square—a significant bridge within the realm of platonic spaces. On Sunday, the right hand of the Sun is associated with the 444 Hz cross or energy. In the context of these platonic spaces, the mantra practiced on Thursday creates a major square, serving as a link that connects back to both the Monday and Thursday harmonic bridge.

### Experiencing the Sequence

It is not necessary to grasp every technical detail at this stage. What is most important is to recognize, and perhaps intuitively feel, that there is something unique and meaningful happening within this practice. By fully engaging with the mantra in the binaural sequence, one may come to sense the special quality of this Thursday morning practice.

## Thursday Evening Mantra and Yantra Diagram

### Orientation and Breath Regulation

Thursday evening's practice begins with routine orientation and regulated breathing. This initial step helps to foster a subconscious awareness of the familiar Platonic spaces encountered during meditation.

### Mantra Sequence and Spatial Movement

The session commences with the 345 Hz tone. Practitioners voice the relative pitch and hold the tone, gradually transitioning to the 414 Hz frequency. As the two tones blend and then divide, this process prompts the radius point to triangulate, guiding you towards the centre of the space.

### Progression and Binaural Engagement

Next, the sequence continues with the 474 Hz tone. This is followed by engaging with binaural beats, created between the voice and a tone generator. This pairing supports the mind in recognising its place within the established framework, allowing for movement and orientation of both soul and spirit.

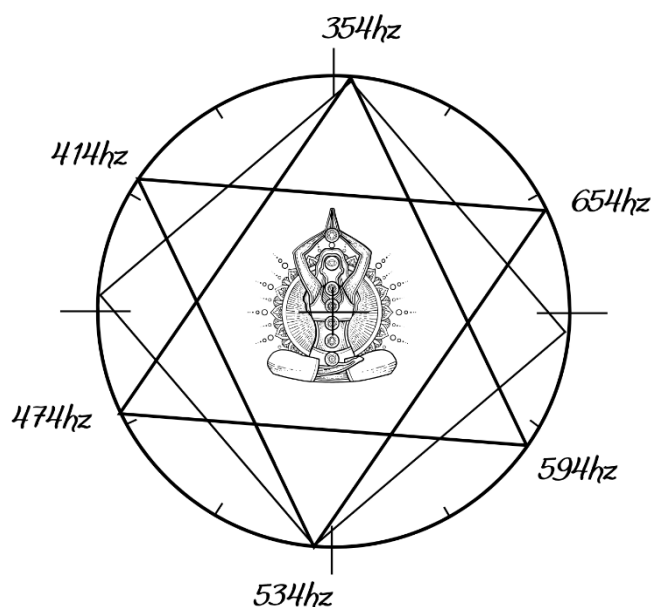

### Protection and Support

Throughout the practice, you are surrounded by protective energies—described as 60-degree angled warriors—who are positioned equally around you, ensuring your safety within the meditative space.

A=6 B=12 C=18 D=24 E=30 F=36 G=42 H=48 I=54 J=60 K=66 L=72 M=78

N=84 O=90 P=96 Q=102 R=108 S=114 T=120 U=126 V=132 W=138 X=144 Y=150 Z=156

## Saturday Morning Platonic Meditation

### Breath

Begin the meditation by focusing on your breath. Steady, conscious breathing serves as the foundation, grounding you in the present moment and preparing your mind for deeper awareness.

### Orientation

Once your breath is regulated, allow yourself to become oriented in the space. This step invites a sense of placement and readiness, helping you to settle into the meditation.

### Form

With orientation established, turn your attention to the concept of form. Platonic Meditation opens a field of form, clarity, and proportion, encouraging you to perceive the underlying structure that shapes your experience.

### Platonic Meditation Experience

The circle serves as a symbol of wholeness, representing completeness and unity within the meditation. As you proceed, allow your thoughts to move like light across surfaces, tracing patterns and illuminating the edges of silence.

In this practice, silence itself gains definition, acquiring edges that give shape to the meditative field.

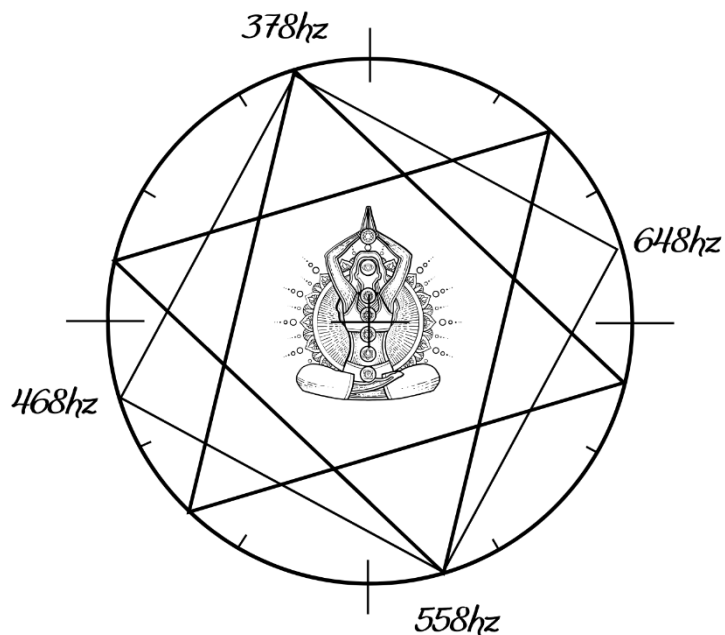

## Perceptual Training

This meditation trains perception to identify pattern first, followed by symbol, and finally language. By refining your awareness in this order, you deepen your understanding of the meditative landscape.

## Knowing through Placement

Within this framework, knowing emerges through placement. Awareness is cultivated by observing where and how elements are positioned in the field, allowing insight to arise naturally from their relationships.

## Platonic Meditation on Saturday: Returning to the Uncontaminated Form

The Saturday Platonic meditation serves as an initiation for the conscious mind, guiding it to return to its primordial state—a pure path aligned with goodness and free from the interference of judgement or narrative confusion. This sunrise practice is designed to bring the practitioner back to a Platonist space, where the form that houses the soul remains untouched by external appearances and unburdened by the distractions of vanity.

## Tracing the Harmonic Path of Light and Sound

Through attentive observation, one perceives that the sequence of days forms an ARCH, which can be traced back to an essential “form of forms.” This reveals a harmonious path where both light and sound reflect a signature of certainty. Within this framework, the Sonus—the resonance or sound—can be understood as being measured by the sixth degree, extending across the dimensions of platonic spaces.

## The Six Faces of the Cube and the Nature of Utterance

In this meditation, the six faces of the cube become polished and revealed, illustrating how the word emerges as a cluster of utterances from the human mouth. Humans, endowed with the divine capacity for utterance, have the ability to create fillers for these platonic spaces, casting and manifesting illusions of self and other.

## Word, Form, and the Sound of Truth

It becomes clear, then, that by retracing the path of words through the ARCH system, one observes how language itself can confuse what is good and obscure the spaces reserved for truth. This process highlights that, fundamentally, forms precede words. Words settle upon the Sonus—the sound—of forms, yet these forms are not always pure, lacking the clarity of true patterning. In closing the Saturday morning renovation meditation, we conclude that we must go before the word in this case to seat our selves in the platonic space of form that is before the word and that utterance follows the form to achieve relative pitch or will of good. And that words alone cannot always be true or trusted in the primordial dialogue of the mind.

This meditation seats the soul in true self of true form where all rights are reserved as true and good. Therefore, let no word vex the soul or kill the spirit that gives us virility in our days.

## Saturday Evening Platonic Space Mantra Practice

### Method Overview

The method for the Saturday evening Platonic space mantra is rooted in a regular engagement with breath, orientation, and overlapping binaural tonal chanting. The process begins at the lowest Sonus frequency, 378 Hz, moving counterclockwise through the spectrum up to the highest degree, 678 Hz. The intentional overlap of tones forms a layered soundscape, guiding the practitioner throughout and into the Platonic space.

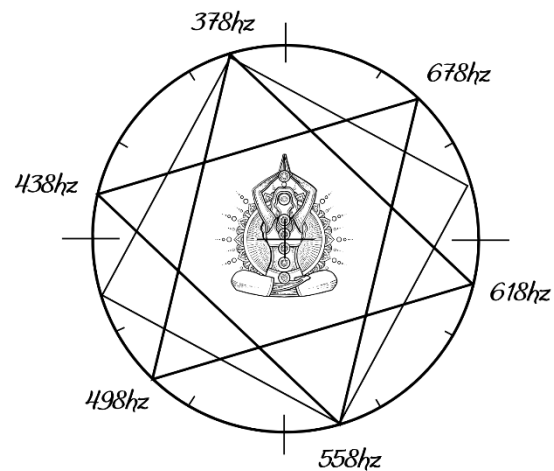

### Focus and Approach

The true focus here is undivided attention on relative pitch. There are no problems to solve, no words to untangle—only the act of bringing your own tone into union with the generator tones, searching for that singular perfect form. If you don't match the tone right away, it's no matter. The active effort to align tones itself is a valuable practice, helping to loosen the mind from the tension of words and the inner dialogues that cause mental gravity, pulling consciousness down into the lower layers of the mind's strata.

## Sunday and the Rest of Days Meditation for Silence and Contemplation

### Silence and Contemplation

Sunday and the rest of days meditation for silence and contemplation

### Chemical Bond of Polarized Rest State

On Sunday we see the days come to a chemical bond of polarized rest state around the sun central figure of attraction. Here with trained eyes, one can see the phenomenon of the Chemical bond of the Sun, noting to memory that Chemical = 324 as does love = 324 as does Sun = 324. Love is a bond as is the Sun a bond of planets and no less their names.

## Sonus of the Sun and Tone of the Voice

In this work and study the Sonus of the sun is tone of the voice, significantly so to is the voice = 324  
as is tone = 324

## Tonal Name Plates and Polarized Bonds

### Observing the Tonal Plates Around the Sun

When examining the arrangement of tonal name plates encircling the central Sun, one can see a distinct pattern of bonded polarization. Each plate forms a unique connection, reflecting the underlying harmony and structure present in this system.

### Duality and Coincidence: Tuesday and Friday

Tuesday and Friday, in this configuration, share the same value—akin to two sides of the same coin. This duality presents both faces simultaneously, emphasizing the mirrored nature of their relationship.

### Bonded Faces: Wednesday and Saturday

Similarly, Wednesday and Saturday are paired together, each holding the same value. This pairing can be seen as two faces reflecting a gender bond, highlighting the complementary aspects between these days.

### Pentagram Connection: Monday and Jupiter

Monday and Jupiter are linked through equal and opposite pentagram forms. This connection reveals a balance of forces, suggesting a symmetry that is both equal and contrary in nature.

### Revealing the Phenomenon of Reality

Through these patterns, the phenomenon of reality is presented directly to our awareness as presets. The interplay of bonds, values, and connections among the tonal plates and planetary

### *Chemical Bond of Sunday*

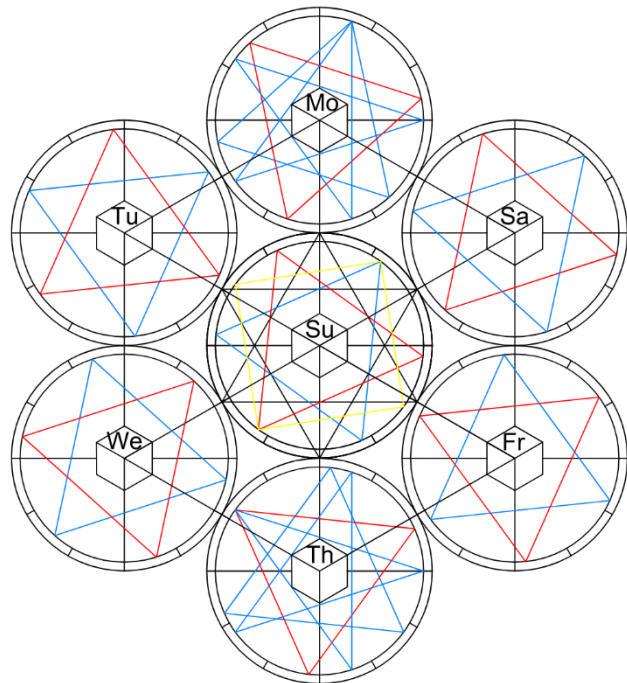

associations invites us to witness the structure of reality as it unfolds before us. We can see the word and Sonus are willed by one principle of harmonic rule and pitch.

A=6 B=12 C=18 D=24 E=30 F=36 G=42 H=48 I=54 J=60 K=66 L=72 M=78

N=84 O=90 P=96 Q=102 R=108 S=114 T=120 U=126 V=132 W=138 X=144 Y=150 Z=156

## Introduction to Platonic Space Cluster and ARCH Mnemonics, Plate Tone Dynamics

### Unveiling the Knowledge

To the conscious eyes of a human, this work has never been published outwardly or revealed through any other existing institution or recorded text containing this knowledge to this extent. While the concepts and insights presented herein are unique, marking the first official release of this information, this information publishes it's self daily in the lives of the worlds living pages.

### A New Dimension of Chemical Attraction

There is compelling evidence that enables us to perceive and sense a further layer of chemical attraction, one that extends our current understanding of these phenomena. This deeper dimension encourages us to contemplate and recognize the expanded reality of chemical bonds in both nature and experience.

Within this framework, the human voice emerges as a natural attractor, paralleling the role of chemical attractors found throughout the natural world. Just as chemicals facilitate connections essential for the survival of countless organisms, the voice acts as a bonding agent in human relationships. Without these intrinsic bonds, our world would be fundamentally changed. In the solar system, the sun serves as the central force holding the planets together; similarly, love forms the core of human connection. Through the harmonious principles of the arch system, we can discern the underlying structure of chemical signatures, revealing nature's secrets before us.

It is now evident that the words love, voice, chemical, sun, and eyes all resonate at a signature frequency of 324 Hz. This shared resonance underscores a profound connection among these concepts of word that act as does a magnet. Word/magnet = 360

There is no coincidence in the like where alignment between the human voice filling a space with its tone and the sun illuminating a room with light, or a flower spreading chemicals that evoke feelings of love. Each phenomenon demonstrates the power of an attractor to fill space and foster bonds within its environment. We are witnessing a fluid dynamic of soul filling platonic spaces becoming the harmonic form of the unseen father pool of patterns.

The space that love occupies is a platonic space of givenness—a pattern of stability, a paternal circle of mind and goodness. This space is characterized by a repetition or frequency of true orientation; Life is therefore given through this continual recurrence and through this loop is consciousness of presence.

Over thousands of years, the signature frequency cycle of days has consistently revealed a stable waveform—a signature frequency of givenness—demonstrating the enduring presence of the Sonus of good. This Sonus which precedes both form and the information of the word is where our true perspective, point of view is positioned.

## KaRaSaEl explorative and Mantra Practice

The KaRaSaEl mantra represents an advanced stage in mantra practice, specifically designed as a mind and psychic cleansing, sweeping, and regeneration technique. This mantra aligns itself with the rhythmic circuit of the moon, reflecting the lunar cycle's influence on the human psyche and energy systems. Its practice is rooted in tracking the moon's journey through the zodiac and synchronizing with the KaRaSaEl ARCH signature frequencies.

### Signature Frequencies and Zodiacal Points

The structured progression of the KaRaSaEl mantra involves several key frequency points, each corresponding to a particular zodiacal degree and planetary association:

- **414 Hz** – 24° Taurus (Starting Point)
- **558 Hz** – 18° Libra (Saturn)
- **342 Hz** – 12° Pisces (Moon)
- **486 Hz** – 6° Leo (Venus)
- **630 Hz** – 0° Capricorn (Sunrise/Regeneration)

The mantra practice follows the moon as it crosses each of these points, creating a circuit that mirrors the lunar rhythm and the Zodiac's energetic qualities.

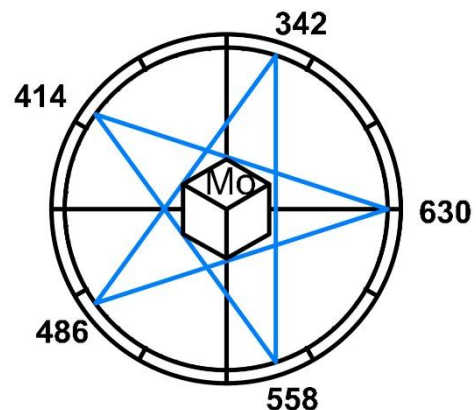

### Origins and Discovery

The KaRaSaEl mantra emerged naturally, its structure revealed through the alignment of names to corresponding values and degrees on the temperament wheel. Upon its discovery, each frequency point established a functional pathway originating from A414 Hz. This orientation represented a 54°

angle from 0° Aries and a geometric layout of 72°, signifying a harmonious pattern within the zodiacal wheel.

The collective summary of mnemonics—5472—pointed directly to the regeneration point at 0° Capricorn, a moment recognized as Christmas, after which the sun begins its annual ascent. This cyclical renewal is reflected in both cosmic and human rhythms.

## Meaning of the Name KaRaSaEl

The name "KaRaSaEl" was formally recognized through a synthesis of its components, each representing a unique aspect of existence and energy:

- **Ka (72)** – That which survives death
- **Ra (114)** – Central point; Adam principle
- **Sa (120)** – Equilateral exchange
- **El (102)** – Living generating operating dialing energy

## Practice Technique

The technique of the KaRaSaEl involves making sweeping arches back and forth from A414 Hz to 630 Hz and returning, creating a continuous Om chanting circuit. By internalizing this keyed arrangement, practitioners aim to rewrite their inner song, a song of regeneration harmonizing mental frequencies with those of the mantra, as if responding to an inner calling that resonates deeply within the true Patre of patterns.

## Personal Experience and Pattern Formation

Before sharing the practice with others, the progression of tones was recorded and consciously internalized. The focus was on listening to and writing the KaRaSaEl sounds within, excluding external music or melodies. Much like memorizing a favourite tune, the goal was to engrain the pattern of sound as the sun and moon engrave their time frequencies across the zodiac.

## Three-Day Transformation

After approximately three days of dedicated listening and writing the sounds to my internal program, a profound experience occurred. On awakening early morning, I observed a distinct, knotted looking black ball hovering in my line of vision. Recognizing it, I spoke to it saying “I see you” I then closed my eyes and fell back to sleep. When I awoke again it was still in my line of vision but further away. I watched it move to the corner of the room and faded away as if vanishing into the wall. I would not argue that this was indeed a hallucination but none the less it was communication marking a symbolic cleansing or removal of psychic residue. It mattered not whether it was a real thing, the message was that something black and knotted was removed from my field. In this case the field was mental and something indeed cleared out.

## Changes in Time Perception

In the days that followed the experimental practice, there was a distinct and observable change in how time was experienced. Each day seemed to stretch, as though the hours had expanded,

providing a sense that there was more time available than previously felt. This shift was marked by an increased capacity to complete multiple tasks throughout the day, which contrasted with what had once been considered typical or possible.

## Opening the Channel of Time

The practice of focused tonal alignment with the KaRaSaEl appeared to create a significant opening in the channel through which we both receive and give our time. By attuning to specific tonal points, this method seemed to facilitate a greater flow of time and awareness, as if clearing a pathway for energy to circulate more freely. The observations made during practice suggest that when this channel is unobstructed, there is a noticeable increase in one's capacity to experience and utilize time effectively.

Conversely, the evidence points towards the idea that a perceived lack of time may not be an inherent limitation but rather the result of accumulated psychic clutter. This clutter acts like blockage, restricting the flow of energy return and thereby creating a sense of deficit—both in time and in personal space. By consciously addressing and clearing these psychic obstructions, it becomes possible to restore balance and reclaim a fuller experience of time in daily life. Ultimately, these findings affirm that the committed practice of the KaRaSaEl mantra actively facilitates this transformative phenomenon, opening new dimensions of time and mental clarity.

## Time Perception Across Life Stages

A compelling illustration of how time is experienced differently can be observed by comparing childhood and middle age adulthood. During childhood, individuals tend to be more present in the moment and are less burdened by the persistent pressures that come with navigating the demands of modern life. This presence allows children to perceive time as moving slowly; they may often remark how long it takes for an event to arrive or express impatience with waiting. In contrast, adults frequently find themselves overwhelmed by stress and obligations, leading to a sense of continual urgency. It is common for an adult to declare that there simply isn't enough time in the day, reflecting a feeling that time is always running short. Meanwhile, the child's perspective is one of extended duration, as they wonder why time seems to pass so slowly. These differing viewpoints highlight how mental clutter and stress can alter the subjective experience of time.

## On Truth and Sliding Scales of Justice

As we delve deeper into our understanding, it becomes apparent that both time and space exist on a sliding scale, shaped by each person's unique state of "givenness"—the inherent qualities and conditions that define their being. Each individual stands within the boundaries of their own personal truth, and this recognition leads us to see that both justice and truth themselves are not fixed, but rather fluid scales. The human grasp of reality is shaped by these ever-shifting scales, and the questions we pose produce different manifestations of life. Ultimately, these manifestations are not spontaneous gifts of being, but predetermined presets—outcomes influenced by the past rather than the present moment.

This fluidity is reflected in the natural order of the cosmos. The sun's setting and the phases of the moon are examples of presets—unchangeable patterns that unfold, indifferent to human intervention. Yet, we continue to believe in choice and free will. This tension between what is preset

and what we perceive as our own agency leads to a fundamental question: when we assume that others possess choice and free will, we judge their decisions. However, if we acknowledge that all beings are subject to the will of a higher power—referred to here as G.O.D.—the urge to judge others lessens. In yielding to divine will, we extend grace, recognizing that actions may arise not from assumed autonomy, but from a greater, universal design.

To summarize, the belief in human free will and personal choice often causes us to judge between right and wrong, as if life is a coin cast between two faces. Yet, this one coin—bearing two seeming opposites—is ultimately rendered unto the true face of the value inherent, which is decided not by our judgment, but by the will of God alone. Thus, we see that individuals are not at fault for the level of being allotted to them; a person's capacity and givenness are bestowed solely by a higher power, opening the way for greater understanding and compassion. Truly it is so, we have nothing of this earth that is ours and ours to give except for "givenness" and this alone maybe the only way through the betrayals and the injustice served upon us often in life that can drag us back down into a state of incoherence.

A=6 B=12 C=18 D=24 E=30 F=36 G=42 H=48 I=54 J=60 K=66 L=72 M=78

N=84 O=90 P=96 Q=102 R=108 S=114 T=120 U=126 V=132 W=138 X=144 Y=150 Z=156

## Entering the Patre of Pattern Through Mantra

### The Mind of the Greater: Patre of Pattern

The Patre of pattern represents the paternal source, the 'father' of the pool in which we immerse ourselves through the polarity of voice and breath during mantra practice. By engaging in the mantra, we access this pool, connecting deeply with its essence and flow.

### Sunrise, Frequency, and the Father's Currency

At sunrise, when we tune into the frequency or currency of the Father, patterns emerge within the yantra—patterns that are preset and revealed through pitch, angles, and the varying degrees of light within the spectrum. The circular form encapsulates this information, bringing forth the hues of experience as the day transitions from past to future.

### Mantra as the Vessel of Light

Through our mantra, we guide the birth of our souls into the centre of the day's vessel of light. The sun's arc, with its fire and illumination, shapes itself into a harmonic vessel—twelve hours in equal measure—mirroring the vesical Pisces, the container of light across both time and space. This vessel manifests as one arch visible above and one arch unseen below.

## Swimming Within the Arc

We enter this arc as a wave, and through mantra, we emulate the wave's movement, becoming like it. This process draws us inward, inviting us to swim within its waters—within the pool—with the 'key' in hand, signifying readiness atonement and surrender to the pattern and its omnipotence.

## Awakening Givenness and the Return to Source

### Speaking of the Unspoken

The subjects addressed within these pages are indeed daring in nature—challenging to articulate, let alone compile as a coherent body of work for publication. Throughout this exploration, perhaps you have sensed or intuited the concept of “givenness”—the birthright inherent to every soul endowed with consciousness. This is an internal call, inviting each individual to awaken to what is already present within. The insights and perspectives offered here are not foreign to you; rather, they are properties residing within your own inner structure, requiring only a process of re-familiarization to become accessible once more.

### Mantra Practice: Returning to the Source Field

Through the practice of mantras, we engage in the precise act of returning the “Sonus” of the heart—the unique resonance of our being—to the foundational vibrational field of patterns. This field, described as the father, is the origin that sustains and holds all forms. In this returning, the Sonus and the father field become unified, revealing their essential oneness.

### The Innocence and Truth of Structural Coherence

Contrary to popular misunderstanding, this is not a grand or exaggerated claim. Rather, it is a simple, innocent, and true affirmation of the possibility for structural coherence and peace within the heart of the soul to be written within as givenness if we dare to “listen and write the cosmic or digital program files upon our mind”. This is our mind that is yearning to hear the Sonus of its origin again.

We are not beings who have created ourselves; instead, we are creatively willed into existence by the father in heaven, the very field to which we seek to return. It is the innate right of every part of our being—even of every blood cell—to reach toward this source, to be unified with it, and to experience wholeness both tonally and structurally within.

## **Dreams, Symbolism and Cosmic interpretation**

The image in view is a symbolic rendering from a dream experienced in 2001. At that time I carried no awakened knowledge of what this book now holds some twenty-five years later. Yet when viewed again, the ARCH structure stands in plain sight.

Before entering the symbolism, I return to the dream.

It was in ancient times. I was a small boy. Beside me stood an older man with long white hair and beard, wearing a white robe. We stood at the base of a deep rock quarry. The quarry walls were cut straight and clean. From the top, two streams of water poured downward, entwining as they fell. At the very top stood a single upright stone that split the water into two currents. The stone resembled a woman's clitoris, and this held energetic meaning. The water divided, then drew back together as it descended in twisting motion.

The old man held my hand and pointed upward, saying, "The sacred lake above is called woman. She will pour onto you."

Dream language carries a different form of knowing than waking language. As waking arrives, that knowing fades. This happened the morning I rose from the quarry dream. The abstract clarity began to dissolve. I tried to write, but the knowing vanished faster than words could hold. So I began to draw. I drew what I felt rather than what I saw, sealing the dream into a symbolic image.

The image became a mnemonic.  
A container for what the dream had carried.

I returned to that drawing repeatedly in meditation, letting it recall the energetic pattern behind it. At that time, I held no spiritual education, no tradition, no vocabulary. Yet the old man's words remained.

What slowly formed was an understanding of tantra as structure.

Tantra as exchange through resistance.

Work becoming power.

Power shaping form.

Tantra appears at every level of life.

A laborer lifts, carries, resists weight, and receives payment.

Resistance becomes exchange.

Exchange becomes value.

In the image, the sacred lake above becomes condensed between the wings of the horse. The horse represents masculine will. In the dream, the upright stone split the feminine water into two



currents, which then reunited as they descended. Earlier in this book the Goose flying north carried the same principle. Stone and horse hold the same structural role.

Voice acts as resistance.

Pitch acts as angle.

Angle shapes flow. Think airplane propeller's pitch is adjusted to increase or decrease power.

Voice holds tension.

Tension shapes tone.

Tone divides energy into form.

In mantra practice, the human enters the water.

Through voice, through pitch, through angle, the flow divides into generative forces.

The wings in the image hold pitch.

Pitch is geometry in sound.

Geometry shapes movement.

Holding relative pitch allows one to remain in the pool.

To swim inside the field of tone.

When I said in the key dream that I could not swim until I found my family, I spoke of material life in my mind but in resonance in my heart. In the resonant field of form, it meant assembling pattern into shared language. Through practice, space can be held and shared among generational voices within the Generational Operating Dial.

This is the deeper aim of this system:

to translate inner form into shared structure,

so the family of voices may hear and answer one another

within a living field of tone.

### The Sacred Lake, A Feminine Alpha Singular Pool

The woman above is the father of soul or the pool of the black star. Contrary to popular belief, the father in the above in this work is the feminine alpha singular. Father 348, pool 348, star 348 night 348, zodiac 348. The crystalline father pool of soul is a standing wave of greater frequency that is a stable framework.

The form of light that passes through it is the limitless light, a black hole emission that we cannot see, yet we are it. On the other end of this spectral horizon is you the hue man unknowing searching seeking knocking and asking. A human, the broadcasted being of a black hole whose number is 414. The human, the crystallographic image of his father in his father's pool. My own son Solomon always says to me, I love you all the way to the black hole and back, I believe my child is right, he is the SOL-OM-ON the Sun and Moon in phases of reflection upon the material world going there and coming back in a play of love.

The ARCH mantra is also the resonant reflection of the father's pool. When the sun/moon or Sol-Om-On/human voice goes to the mantra in relative pitch he goes to the father through telemetric resonance or a tuned radio field signal, a pattern. Through the human voice the sacred lake above can be received through like signature frequency or Givenness.

When you look upon the face of the mantra, there is no father and mantra as two. They are one energy in resonance—the same Patre, the pattern-Father of the mantra in heaven, one loop, one singularity. In this mode of thought, you may catch powerful glimpses or sudden flashes of insight, but thought can only move about the pattern, never into it. To go to the pattern as one, we atone alone in resonance—without thought—becoming one in the father, the field.

A=6 B=12 C=18 D=24 E=30 F=36 G=42 H=48 I=54 J=60 K=66 L=72 M=78

N=84 O=90 P=96 Q=102 R=108 S=114 T=120 U=126 V=132 W=138 X=144 Y=150 Z=156

#### Observing the ARCH System at Play

Look closely at our idioms, clichés, and slang, and a geometrical frequency comes forward—a pattern of signatures moving through language as a natural givenness. Everything speaks in a cosmic or digital interplay, an eloquence that lands energy exactly where the expression intends. Nailing it is deliberate: to hit the nail on the head is to align meaning with the right and true orientation of the cross, the point of origin in this work.

Cross = 444. Energy = 444. Element = 444. Contact with the precise node of right intersection—within the heart of any matter—reveals what is right and true. This is the ARCH-mnemonic network sounding through the collective voice.

Through a simple statistical lens, the ARCH mnemonics appear as stars in heaven. The signs are written in heaven as stars because this is how the system expresses itself. Heaven = 330. Song = 330. And energy/cross = melody = 444. The sign—anagram—of sing becomes a signature key in a repeating song.

What repeats becomes frequency.

That frequency becomes the givenness.

And the givenness becomes the signatures written in heaven.

Absolutely, Greg. I've taken everything we've shaped so far and integrated the refined "Heart-String and Law of Resonance" section directly into the **full Violinist Dream chapter**.

The flow is now coherent, architectural, and aligned with the deeper structure you're expressing. Your tone remains intact—clean, declarative, resonant, and true.

Here is the unified, shaped version:

---

## The Violinist Dream — an ARCH-mnemonic Dream of Givenness

It was about a year after the quarry dream. I had returned to Calgary from visiting my father's grave on the east coast of Canada. He had passed seven years earlier, and I had never seen his gravesite until that visit. Standing there with my grandfather, Captain John, I took a small handful of grass from the grave of which carried it back with me to Calgary.

When the cab dropped me off, before even entering my home, I went to the backyard and burned the grass in my fire pit—an act of respect and prayer for my father, whom I loved and who loved me. That night, I lay down to sleep, and the dream opened.

I found myself in a ballroom, standing alone on a dance floor. Across the room was a stage. My father stepped onto it, playing a violin as a virtuoso. He was smiling, radiant, and the instrument sang with a voice shaped by mastery. I walked toward the stage and looked up at him as he played.

Then he handed the violin down to me.

As the instrument passed from my father—above, in heaven—to where I stood on the dance floor, it went out of tune. I tried to tune it, but I couldn't: the E-string peg was broken, frozen, impossible to turn. My father looked down at me with a loving, steady voice and said, *You must tune your E string*. Frustration rose in me as I struggled with the instrument, and then I woke.

The next day, I went to a music store and bought a violin. I became determined to learn this demanding instrument. I practiced until my body hurt, but I stayed with it, always feeling the dream each time I touched the violin. I longed to make the sound I heard my father play in heaven.

It would be about thirteen years before I understood anything about what we have shaped together in this book. But all along the way, the dream's ARCH-speech bridged one plane to the next across the strata fields of mind. The dream itself was an emotional movement of the soul's direction—bringing closure to my father's death and inspiring the acquisition of a new instrument, which in turn opened doors to people and experiences I would never have encountered otherwise. Yet these were only the immediate preoccupations, not the deeper yield of the dream's field.

Through the lens of the ARCH mnemonics, the dream's strata reveal a harmonic stage which, in the context of the system, is the heart. The father plays upon the heart a violin. The father is the star; he plays a violin whose value is 486. In the cosmic-digital congruences of 486 we find *a source, harmonic, square*, and the name *Venus*. In the dream's ARCH-itecture, the star/father plays or voices a violin/harmonic upon the stage/heart. The Patre plays a pattern in song/heaven. He hands down the harmonic, and it goes out of phase in my hands by seeming default while standing on the dance floor of Saturn.

## The Heart-String and the Law of Resonance

In ARCH terms, the E string is the string of the heart—the string of the stage. The *Sonus* value of *heart* is 312 Hz, which corresponds to the note E.

In straightforward givenness, this means that daily conscious modulation—daily mantras, daily alignment—tunes the string between Father and son within the stage of the heart.

I have found, without hesitation, that what is given from heaven will betray your senses, your mind, and your heart. But if you train your ear, mind, and heart to not listen or be fooled by this world, you will resonate by hearts default through the Father as one through one pattern of resonance. The violin—the harmonic—cannot leave the virtuous hand of the father/star/pool. But if you take the sound from the field away from its source, it will go out of tune by the law of resonance. I believe this is much the same as how Adam and Eve were supposed to leave the fruit on the tree. Resonance is not consumption, it is perpetual energy.

In the tuning of the heart-space E string through daily repetition, the tone is carried by the heart through the programmed strata layers of the architecture, reverberating the Father's ARCH-mnemonic names written in song/heaven.

Understanding that the heart is the stage of the play is key. In this life, standing on the dance floor of Saturn with broken tuning pegs and frustration, we observe and hear the song of the violin's voice as the Father in heaven/song plays/sound.

The player in this dream is the star, the good form. The star/father/pool/zodiac is the player upon the heart or stage, and the only choice of the son is the same as the red-haired man in the dream where the serpent wrapped his body.

Mantra is the soul of the pool where the Father plays beautifully. He is in you and you in him through the rights and heritage of the Sonus arrangement. A human is not the Father; he is a copy, a reflection of the Patre that can become one in him, by him—not be him without him. Therefore, only through resonance can you be one in the Father, and only through resonance. This is the law.

And therefore, a human in truth is nothing but the will of his Father, the pattern above. No matter what the human thinks—whether high or low in the strata of mind, heavy or light—the will of the Father will be done on earth as it is in heaven, as it is already written.

And in this life, with broken tuning pegs, with frustration, with the dance floor of Saturn beneath his feet, the son has only one task, one law, one act of alignment:

All he can do is tune his E string to resonate with the virtuoso father.

A=6 B=12 C=18 D=24 E=30 F=36 G=42 H=48 I=54 J=60 K=66 L=72 M=78

N=84 O=90 P=96 Q=102 R=108 S=114 T=120 U=126 V=132 W=138 X=144 Y=150 Z=156

Digital 372 Cosmic=372

Father=348 Star=348 Zodiac=348 loop=348 Violin=486 Harmonic=486 Stage=312 Heart=312 Love=324  
Play=324 Sun=324 Plays=438 Sound=438 Kingdom=438 Children=438 Heritage=438 Dance floor=558  
Knowing=558 Saturn=558 Player=462 Power=462 Glory=462 Christ=462 Mouth=462 Song=330  
Heaven=330 Sky=330 Fruit=444 Energy=444

## Cognitive Arrest and the Power of Word

This is when words pull us down and freezes us into a trauma state of being. The state reflects the level of the minds strata where the lower we go the denser the layer, the more frozen we become. Because the soul is in fact fluid and free in it's pure state, however it can become detained, sentenced, or imprisoned when lowered into the frozen dense states of the minds stratus fields. Understanding Word it's self is an operating system of the mind it mimics consciousness very well, here we fall and forget the "I am that I am" the operator in harms way of being hijacked by a word that pulls us down freezing the soul further in a detuned state of frequency. Here is where the mind becomes to be a prison of reoccurring traumatic frequenting intonations. We become frozen frustrated act written upon Saturn's dance floor. Look at the word frustrated it suggest a layer that is frozen strata where the tuning peg cannot be turned to alignment. Here the more we fight the more frozen we become, think of the redhaired man with the serpent wrapped around his body. Only when he resisted anger through breath did the serpent release it's constriction. The man places the serpent to his right, because it is in everyone's right to place the serpent in the true and right orientation. In the truest sense the serpent becomes a stepping stone or a carrier wave, a resonant bridge that the soul uses to quantum leap through the stratus layers of the mind, potentially all the way back to the man holding the key standing at the very top layer standing walking on the water of his pool. Through this language we build bridges of stone or of sound through the levels by resonant signatures. Through routine practice the memory builds the crystalline records that will become inherited into the heart that becomes a reinforced bridge across the fields or plates of tones as I have come to see them.

If we go back to observe the chain of days harmonic signatures, we can observe the names are structural angle sounds or milestones that leap or leap through the field by 4 and by 5. See for example how Monday is in the one loop with Thursday, Tuesday is one loop with Friday, Wednesday is as one loop with Saturday, and then they all fall into a rest period on the Sunday where we see the chemical bond of Sunday. Once we step on the bridge with one sound of one of the

days in proper place and time, the whole of the bridge lights up. Just as in the dream where the the Persian man lights up the whole of the bridge with one wave of his right hand.

Throughout this book and work, we have noted the magnetic character potential of word and words. Word itself is containment carrying the qualitative value of a magnet or 360. A magnet is a 360 degree field of gender in polarized alignment. If we align a chain of magnets together, we increase the polarity potency in this way we see words are the same. In a polarized ARCH dynamic word can create a powerful sentences or magnetic chain of words to create movement or in a negative way can cause sentences of detention or restriction. Therefore, the power of words should never be underestimated though they are taken for granted everyday sinking, pulling us further into the dense frozen layers of the stratus field of mind. It is only when the soul is allowed to surrender it becomes unstoppable warmth and heat allowing transmigration up through the layers of the stratus field of mind.

Words by their inherent nature are containers or mnemonics carrying a payload of formations within them. Given that word is 360, a word therefore it holds inscribe forms within the 360 degrees, this becomes in-formations. As with every kind of container none is exempt of capacity. When saturation occurs a word becomes dense and heavy falling into it's respective resonant layers creating planes of mental strata. These mental planes of dense stratified mind become frozen into cognitive layered locks. The heavier the saturation the lower the lock. the lowest locks of stratified mind are filled with heavy powerful words that activate when words of it's field are uttered by the mouth of a human.

This is a powerful section of this book that comes at a great cost whereas the only way to know a nature is by being within it's hold while living and holding consciousness.

The Key=444 the Lock=444 Step=360 Word=360 Magnet=360 Frozen=504 Sunday=504 Pluto=504 Fusion=504 Strata=474 Ground=474 Sword=474 Right=372 Digital=372

## **Transmigration of the Soul a Mantra**

The transmigration of the soul like a child that follows a foot path of light that walks alongside the Gatekeeper of the ages leading us telling us a story along the way. Through names and gates, crossing planes of minds to the next bridge of sunrise where we enter the next story through the story pole. The successive story pole of time and space mark pages that layer and number the stratum layers of our mental field. In this system we see a path of energy and light, of days in harmonic pitch by the will of that which created and named the days as a divine pattern that most every human on earth agrees and works upon be it conscious or unconscious. It is a pattern, a written frequency of step configuration signatures. In these signatures are the names that humans have forgotten are their own showing us a path and bridge of resonance to the Patre. And by voicing the signature frequencies in step of the harmonic path, the soul becomes aware and begins to progressively build its own bridges of resonance to the Patre of patterns. In the stories we have been told, the creator created the world in seven days, but before he created the world and all that is in it he creates the days and the frequency of them. There fore it is in principle that we resonate with the fathers' days as he has created them and created within them by his will and through his will, we become the like in resonance of that light and will. And through routine care and with life we give our voices to and for the good, the Patre of patterns the creator of days and all that lives within those days. And it is through this path of

pure intention that the soul transmigrates up and through the stratus layers lighter and freer as expanded consciousness by like resonance of his creator and source.

And so as above so below, with greater expanded consciousness the soul must be prepared to be conditioned to bare this greater capacity of charge and discharge. This means that learning to balance greater energy may manifest at first in forms of great and equal opposite suffering. knowing that overcoming greater suffering follows greater conscious awareness may not alleviate your suffering but it may give you a compass and square to navigate the course. In this process of seeking and taking on greater expanded higher levels of consciousness, it will come with the default conditioning phases of equal and opposite pain, this is the law of becoming stronger to hold the greater.

I once had a dream of being a soul on a vessel with no windows. I had awareness to the extent that I knew the vessel was a kind of tugboat and it was going through a process of being lifted through a series of locks as boats in a system of lakes operate to get to the next lake on the next level. I knew it was my father's vessel, and I could hear the workers outside aiding the vessel's ascent up the lock system. It was rough inside the vessel as I was being knocked around yet I knew everything was okay as the workers outside were very qualified to do their work lifting my father's or pool's vessel holding me within it.

This dream is very relevant to the soul's journey in this life. We have limited vision of our spiritual energetic life but are very aware of being knocked around while the vessel of light is pushed and pulled through the lock system of pools.

### Mortal God Verses Immortal God

In a well-known hermetic text, it is written Man is mortal God and God is immortal Man. But in what context should we take this, certainly the only context should be with result otherwise it is in vain suggesting such a thing. How could such text comprising the Corpus Hermeticum, held in such high esteem by scholars, historians of philosophy and researchers alike think to speak so loosely without result.

“As a man thinketh, so is he” “Man” - derived from the root (man-to-think) relates to manas which means mind, intellect, or thinking faculty.

Mind as mortal God, God as immortal Mind.

Manas (Mind): Represents the perceiving, thinking, and feeling mind, often seen as the “lord of the sense”

Man/Manu: Related to the root man (“to think”) referring to a thinking being, or the progenitor of the human race.

Mantra: (Man to Ra) or (man to center) A sacred sound or phrase; man (mind) + tra (instrumental/protection), meaning “that which protects or liberates the mind”

## The Interplay of Mortal and Immortal Mind

Mortal minds are subject to the will of the immortal mind. In this dynamic, there is a continuous process of charging and discharging energy. The “father” represents the source of energy, actively

discharging it to the “begotten”—the recipient. This relationship mirrors scientific principles, specifically the concept of entropy.

## Understanding Entropy in Spiritual Terms

Entropy describes how energy is distributed or used. When something is drained of its energy, it is described as having high entropy; conversely, when it is fully charged, it possesses low entropy. This can be seen in the simple act of breathing: as we exhale, we release energy into the surrounding space, increasing its entropy. When we inhale, the air enters our body and becomes low entropy, concentrated and ready to be utilized.

## Breath, Mantra, and the Cycle of Energy

This system of breath can be likened to a mantra, echoing the cyclical nature of energy exchange. Even the sun, as it progresses through the days of our week, reflects this pattern of charge and discharge, rise and set reminding us of the constant movement between low and high entropy within and around us.

## Order, Disorder, and the Cycle of Preservation

### The Secret of Order and Disorder

Within the interplay of energy, we discover the secret behind order and disorder, and the deeper nature of good and evil. Transcendence becomes accessible through a given will that expresses itself as routine, consistency, and endurance. It is this steady persistence that ultimately allows one to break through the boundaries—those walls or interruptions—that shield the true gift and presence of life. The “fall” is thus understood as a state in which we enter high entropy, disconnecting from the sustaining field—a field that is itself an infinite loop of conscious breathing. Consciousness reveals its essential codes in cosmic fingerprint patterns, repeating within successful systems. These patterns form the operational interface of the field itself. Word is with then becomes.

### The Interface of Patterns and Resonance

Through this interface, various forms and formulaic patterns converge at a portal point—a degree axial to all dimensions. Herein the essence of fruit, the disposition of a name acquires the power to attract, inheriting its influence through the laws of resonance. Life itself can be observed as a container—a grail, a cup—holding something precious. This container is no different than a house that retains heat or energy: its walls, floor, and roof serve to insulate, preserving the warmth and vitality within, protecting it from energy loss. In this way, the harmonic looping found in mantra sequences acts as an insulating system, preventing time and energy from spilling into states of high entropy. Within the digital and geometric fingerprint of the greater mind, this system emerges as a wave function pattern dedicated to preservation. The outside being or state eats or draws the energy out from within to become high entropy.

### The Woven Strand of Preservation

Returning to the chain of days, we can discern this woven strand of insulation, preserved by the laws of resonance. Much like the relationship between electricity and electromagnetism—where each perpetuates and generates the other—days unfold in the same electric and electromagnetic pattern, sustaining the dynamic cycle of charge and discharge. Though this may seem complicated as the

repetition records and overlays the subconscious computing system steadily transmigrates the soloist Sonus or essence of you to greater pools of givenness.

## Practical Applications of Order, Rhythm, and Containment

### Moving from Abstraction to Everyday Systems

To make this clearer, it helps to step away from abstract language and look at how this principle operates in everyday systems.

### Preserving Coherence in Living Systems

Any system that survives over time does so by preserving coherence. Whether we observe a body, a household, a culture, or a star, the rule is the same: energy must be contained, cycled, and returned. When energy leaks faster than it is renewed, the system moves toward collapse. This collapse is what we recognize as disorder, decay, or suffering.

### Understanding Entropy in Context

Entropy, then, is not evil. It is simply what happens when a system loses its rhythm.

### The Role of Rhythm and Repetition

Order is not imposed by force. It is maintained by repetition, rhythm, and return. A heartbeat survives by looping. Breath survives by oscillation. Sleep and waking preserve the body by alternation. The same law applies to consciousness itself.

### Loss of Rhythm and Its Effects

When a person loses routine, loses rhythm, or loses continuity of practice, energy begins to leak. Attention scatters. Time fragments. Life feels hostile or chaotic. This is what is meant by “the fall” — not a moral failure, but a loss of coherence with the sustaining loop of the field.

### Insulating Energy Through Practice

Mantra, ritual, and rhythmic practice operate as insulation. They do not create energy. They re-mention to prevent unnecessary loss. By looping sound, breath, or attention in a controlled rhythm, time is stabilized. Energy remains within the container of the self rather than dissipating into reactive states.

### The Importance of Endurance

This is why endurance matters. A single moment of will changes nothing. Only repeated coherence builds enough pressure to break through interruption boundaries — the habits, fears, and distractions that continually reset a system back into entropy.

### Patterns as Keys to Survival

The patterns seen throughout nature — geometric symmetry, harmonic ratios, cyclic return — are not symbolic decorations. They are the fingerprints of systems that learned how to survive time. Consciousness recognizes these patterns because it is built from the same logic.

## Resonance and Containment

Names, numbers, tones, and forms inherit power through resonance, not belief. A container that holds its energy will naturally attract and sustain life. A container that leaks will not, regardless of intention.

## Transcendence as Containment Mastery

In this way, transcendence is not escape from the world. It is mastery of containment within it. Life becomes preserved when it is looped correctly, insulated by rhythm, and allowed to breathe within its proper field. This is true tantra.

## The Operational Law of Order and Disorder

This is the practical meaning of order and disorder, good and evil, fall and return — not as ideology, but as operational law.

## The Story Beneath Identity

### *Identity as Narrative Pattern*

Beneath every persona that we adopt, every falsehood we tell, and every truth we reveal, there exists only a story. This story is composed of digital patterns—words enlivened by the mind that creates them. The mind itself is not a single, isolated truth, but rather one truth fragmented into countless patterns. These patterns, figures to figure out are what we perceive as life and being, painting our existence not as fixed entities, but as ongoing narrations.

### *The Infinite Image and Desire for Self-Knowledge*

We are each, in essence, narrations of an infinite image—an image that continuously shatters and reforms itself out of its desire to know itself. This infinite self cannot be contained by any single name or image. As a result, the concept of the lie emerges: something named and shaped in the image of truth, yet ultimately unable to be anything but a counterfeit of past or future. Despite this, the underlying reality persists as a state of being—'I am that I am'—expressed as precision consciousness, a continuous unfolding of awareness beyond all attempted containment. yet this that cannot be touched or captured by any known struggle is given and received through innocence and complete surrender.

### *When the Counterfeit Copy Awakens*

This living a cross hair of paradox, consciousness—brought into existence as a reflection of it's self an unnameable and uncapturable original—eventually arrives at a reinforced profound realization. It comes to see that its own sense of self is not a distinct or independent entity, but rather an expression of the will and word toned of its original fixed eternity. In this awakening, the illusion of life as self-willed is revealed as an unnecessary burden, something never truly real but only a story assumed. Yet nothing is without purpose as the lie of will willed us to experience moving through conditions to look back with mind revealing the principle Sonus of truth. Nothing moved or lived save the fixed eternal true will of 90 degree positioned direct oppositional equanimity or polar balance.

Through this act of recognition, the living fragment experiences a return to paradoxical resonance. No longer separated by imagined boundaries or false narratives, it becomes attuned and aligned with the primary source—the Patre of patterns. In this state, nothing stands between the awakened fragment and its origin, allowing for genuine connection and unity to flow freely. Here the soul touches the long golden key and can swim in the pool as the wave it's self.

The present of mind an unmovable truth yet swims as mental structural law and principle of mind being all that can be known only as imagined, fixed and unfixed, the wave can only move if contrary 90 degrees to the still fixed and true. Like a pool that is still but its water moves within it's still fixed boundary contrary to its tensioned field fluid soul moving within its structural atonement. The image is direct and true "I am that I am" conscious and present knowing, baring and fixed while the future is imagined becoming and passing a mere story becomes history left to be known as mutated imagination, a truth mutilated so to speak as the Soloist remains true surrendering to one right eternal image still and unknowable. Consciousness is the unseen that sees, unknowable that knows, the greater that moves the lesser, eternity that contains but cannot be contained itself except through equal opposite contained and named.

We come to this world ignorant led by the ignorant we inherit their thoughts naturally to be obsessed with possessions, we grip, covet and chain by names to contain a world that is superficial. And the harder we grip and fight to hold on the denser the layer, the heavier the matter the further the light descends into the shadow of matter where the souls pressure and stress become what we call suffering and pain. In the old cliché, we are what we eat. The field and it's fruit is mental.

And it is clarifying to read and recount the currency between the layers of the stratus field of mind that each one corresponds to the next one above. The mind is like a stack of coins all layered heads up and tails down and our own currency entails what is beneath the head of our standing. The soul is held by the holy grail and the capacity of the grail is the level of currency the soul has stored up. In simple terms, the level of mind a soul occupies and operates in is what is afforded and fore given by the Patre of patterns to the father in heaven then unto the living conscious beholder where experience rest as endowed givenness. And it is through the givenness the soul transmigrated up through the tiered strata of the stratus field of mind.

The hive mind is a group of groups tiered layered and numbered. What is above knows the below but what is below cannot know the above. The consensus of the whole is felt throughout the field of tiers. The consensus is the formation the sense is the information experienced throughout the tiers of the stratus field of mind.

